

- (A) $\frac{bh\sigma_y}{4}$ (B) $\frac{2bh\sigma_y}{9}$
 (C) $\frac{bh\sigma_y}{2}$ (D) $\frac{bh\sigma_y}{3}$

Question. 4

Solution for the system defined by the set of equations $4y + 3z = 8$; $2x - z = 2$ and $3x + 2y = 5$ is

- (A) $x = 0; y = 1; z = \frac{4}{3}$ (B) $x = 0; y = \frac{1}{2}; z = 2$
 (C) $x = 1; y = \frac{1}{2}; z = 2$ (D) non-existent

Question. 5

The differential equation $dy/dx = 0.25y^2$ is to be solved using the backward (implicit) Euler's method with the boundary condition $y = 1$ at $x = 0$ and with the a step size of 1. What would be the value of y at $x = 1$?

- (A) 1.33 (B) 1.67
 (C) 2.00 (D) 2.33

Question. 6

For a given matrix $A = \begin{bmatrix} 2 & -2 & 3 \\ -2 & -1 & 6 \\ 1 & 2 & 0 \end{bmatrix}$, one of the eigenvalues is 3.

The other two eigenvalues are

- (A) 2, -5 (B) 3, -5

(C) 2, 5

(D) 3, 5

Question. 7

The directional derivative of $f(x, y, z) = 2x^2 + 3y^2 + z^2$ at the point $P(2, 1, 3)$ in the direction of the vector $a = i - 2k$ is

(A) -2.785 (B) -2.145 (C) -1.789 (D) 1.000 **Question. 8**

A class of first year B. Tech. students is composed of four batches A, B, C and D, each consisting of 30 students. It is found that the sessional marks of students in Engineering Drawing in batch C have a mean of 6.6 and standard deviation of 2.3. The mean and standard deviation of the marks for the entire class are 5.5 and 4.2, respectively. It is decided by the course instructor to normalize the marks of the students of all batches to have the same mean and standard deviation as that of the entire class. Due to this, the marks of a student in batch C are changed from 8.5 to

(A) 6.0

(B) 7.0

(C) 8.0

(D) 9.0

Question. 9

A 2nd degree polynomial, $f(x)$ has values of 1, 4 and 15 at $x = 0, 1$ and 2 , respectively. The integral $\int_0^2 f(x) dx$ is to be estimated by applying the trapezoidal rule to this data. What is the error (defined as “ true value - approximate value”) in the estimate ?

(A) $-\frac{4}{3}$ (B) $-\frac{2}{3}$

(C) 0

(D) $\frac{2}{3}$ **Question. 10**

What is the area common to the circles $r = a$ and $r = 2a \cos \theta$?

(A) $0.524 a^2$ (B) $0.614 a^2$ (C) $1.047 a^2$ (D) $1.228 a^2$

Question. 11

Using Cauchy's integral theorem, the value of the integral (integration being taken in counterclockwise direction) $\oint_c \frac{z^3 - 6}{3z - i} dz$ is

- (A) $\frac{2\pi}{81} - 4\pi i$ (B) $\frac{\pi}{8} - 6\pi i$
(C) $\frac{4\pi}{81} - 6\pi i$ (D) 1

Question. 12

There are 25 calculators in a box. Two of them are defective. Suppose 5 calculators are randomly picked for inspection (i.e., each has the same chance of being selected), what is the probability that only one of the defective calculators will be included in the inspection?

- (A) $\frac{1}{2}$ (B) $\frac{1}{3}$
(C) $\frac{1}{4}$ (D) $\frac{1}{5}$

Question. 13

A spherical naphthalene ball exposed to the atmosphere loses volume at a rate proportional to its instantaneous surface area due to evaporation. If the initial diameter of the ball is 2 m and the diameter reduces to 1 cm after 3 months, the ball completely evaporates in

- (A) 6 months (B) 9 months
(C) 12 months (D) Infinite time

Question. 14

The solution of the differential equation, $x^2 \frac{dy}{dx} + 2xy - x + 1 = 0$, given that at $x = 1$, $y = 0$ is

- (A) $\frac{1}{2} - \frac{1}{x} + \frac{1}{2x^2}$ (B) $\frac{1}{2} - \frac{1}{x} - \frac{1}{2x^2}$
(C) $\frac{1}{2} + \frac{1}{x} + \frac{1}{2x^2}$ (D) $-\frac{1}{2} + \frac{1}{x} + \frac{1}{2x^2}$

Question. 15

A synthetic sample of water is prepared by adding 100 mg Kaolinite (a clay mineral), 200 mg glucose, 168 mg NaCl, 120 mg $MgSO_4$, and 11 mg $CaCl_2$ to 1 litre of pure water. The concentrations of total solids (TS) and fixed dissolved solids (FDS) respectively in the solution in mg/L are equal to

- (A) 699 and 599 (B) 599 and 399
(C) 699 and 199 (D) 699 and 399

Question. 16

To determine the BOD_5 of a waste water sample, 5, 10 and 50 mL aliquots of the waste water were dilute to 300 mL and incubated at $20^\circ C$ in BOD bottles for 5 days. The results were as follows

S.No.	Waste - water volume, mL	Initial DO mg/L	DO after 5 days mg/L
1.	5	9.2	6.9
2.	10	9.1	4.4
3.	50	8.4	0.0

Based on the data, the average BOD_5 of the waste water is equal to

- (A) 139.5 mg/L (B) 126.5 mg/L
(C) 109.8 mg/L (D) 72.2 mg/L

Question. 17

The cumulative noise power distribution curve at a certain location is given below

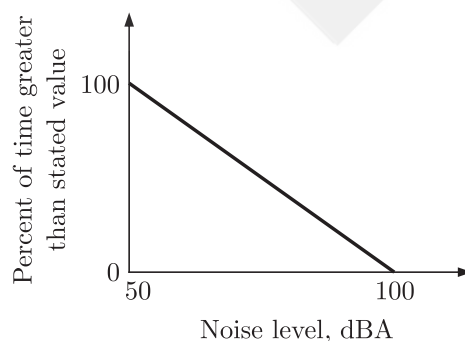

The value of L_{40} is equal to

- (A) 90 dBA (B) 80 dBA
(C) 70 dBA (D) 60 dBA

Question. 18

The composition of a certain MSW sample and specific weights of its various components are given below :

Component	Per cent by weight	Specific weight (kg/m ³)
Food	50	300
Dirt and Ash	30	500
Plastics	10	65
Wood and Yard waste	10	125

Specific weight (kg/m³) of the MSW sample is

- (A) 319 (B) 217
(C) 206 (D) 199

Question. 19

The main indoor airborne Chloroform (CHCl_3) concentration in a room was determine to be $0.4\mu\text{g}/\text{m}^3$

Use the following data : $T = 293 \text{ K}$, $P = 1 \text{ atmosphere}$,

$$R = 82.05 \times 10^{-6} \text{ atm}\cdot\text{m}^3/\text{mol}\cdot\text{K}.$$

Atomic weight : $\text{C} = 12, \text{H} = 1, \text{Cl} = 35.5$.

This concentration expressed in parts per billion (volume basis, ppbv) is equal to

- (A) 1.00 ppbv (B) 0.20 ppbv
(C) 0.10 ppbv (D) 0.08 ppbv

Common Data for Questions 20 and 21 :

In a rapid sand filter, the time for reaching particle break through (T_B) is defined as the time elapsed from start of filter run to the time at which the turbidity of the effluent from the filter is greater than 2.5 NTU. The time for reaching terminal head loss (T_H) is defined as the time elapsed from the start of the filter run to the time when head loss across the filter is greater than 3 m.

Question. 20

The effect of increasing the filter depth (while keeping all other conditions same) on T_B and T_H is

- (A) T_B increases and T_H decreases
- (B) both T_B and T_H increase
- (C) T_B decreases and T_H increases
- (D) both T_B and T_H decrease

Question. 21

The effect of increasing the filter loading rate (while keeping all other conditions same) on T_B and T_H is

- (A) T_B increases and T_H decreases
- (B) both T_B and T_H increase
- (C) T_B decreases and T_H decrease

Statement for Linked Answer Question 22 and 23 :

A water contains the following dissolved ions;

$$[Na^+] = 56 \text{ mg/L}; [Ca^{2+}] = 40 \text{ mg/L};$$

$$[Mg^{2+}] = 30 \text{ mg/L}; [Al^{3+}] = 3 \text{ mg/L};$$

$$[HCO_3^-] = 190 \text{ mg/L}; [Cl^-] = 165 \text{ mg/L}$$

Water pH is 7

Atomic weights: Ca : 40; Mg : 24; Al : 27; H : 1; C : 12; O : 16; Na : 23; Cl : 35.5

Question. 22

The total hardness of the sample in mg/L as CaCO_3 is

- (A) 484 (B) 450
(C) 242 (D) 225

Question. 23

The non-carbonate hardness of the sample in mg/L as CaCO_3 is

- (A) 225 (B) 156
(C) 86 (D) 0

Question. 24

The velocity field for a flow is given by :

$\vec{V} = (5x + 6y + 7z)\hat{i} + (6x + 5y + 9z)\hat{j} + (3x + 2y + \lambda z)\hat{k}$ and the density varies as $\rho = \rho_0 \exp(-2t)$. In order that the mass is conserved, the value of λ should be

- (A) -12 (B) -10
(C) -8 (D) 10

Question. 25

A hydraulic jump occurs in a rectangular, horizontal, frictionless channel. What would be the pre-jump depth if the discharge per unit width is $2 \text{ m}^3/\text{s}/\text{m}$ and the energy loss is 1 m ?

- (A) 0.2 m (B) 0.3 m
(C) 0.8 m (D) 3.20 m

Question. 26

The flow of glycerin (kinematic viscosity $\nu = 5 \times 10^{-4} \text{ m}^2/\text{s}$) in an open channel is to be modeled in a laboratory flume using water ($\nu = 10^{-6} \text{ m}^2/\text{s}$) as the flowing fluid. If both gravity and viscosity are important, what should be the length scale (i.e. ratio of prototype to model dimensions) for maintaining dynamic similarity ?

- (A) 1 (B) 22
(C) 63 (D) 500

Question. 27

The thickness of the laminar boundary layer on a flat plate at a point A is 2 cm and at a point B, 1 m downstream of A from the leading edge of the plate ?

- (A) 0.50 m (B) 0.80 m
(C) 1.00 m (D) 1.25 m

Common Data for Questions 28 and 29

An upward flow of oil (mass density 800 kg/m^3 , dynamic viscosity 0.8 kg/m/s) takes place under laminar conditions in an inclined pipe of 0.1 m diameter as shown in the figure. The pressures at sections 1 and 2 are measured as $p_1 = 435 \text{ kN/m}^2$ and $p_2 = 200 \text{ kN/m}^2$.

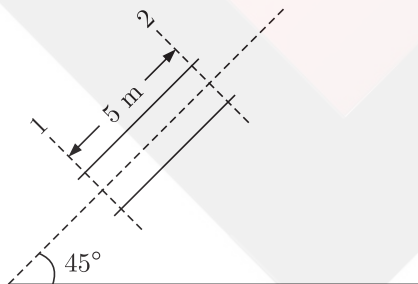
**Question. 28**

The discharge in the pipe as equal to

- (A) $0.100 \text{ m}^3/\text{s}$ (B) $0.127 \text{ m}^3/\text{s}$
(C) $0.144 \text{ m}^3/\text{s}$ (D) $0.161 \text{ m}^3/\text{s}$

Question. 29

If the flow is reversed, keeping the same discharge and the pressure at section 1 is maintained as 435 kN/m^2 , the pressure at section 2 is equal to

- (A) 488 kN/m^2 (B) 549 kN/m^2
 (C) 586 kN/m^2 (D) 614 kN/m^2

Question. 30

Which of the following statement is Not in the context of capillary pressure in solids ?

- (A) Water is under tension in capillary zone
 (B) Pore water pressure is negative in capillary zone
 (C) Effective stress increases due to the capillary zone
 (D) Capillary pressure is more in coarse grained soils

Question. 31

For steady flow to a fully penetrating well in a confined aquifer, the draw downs at radial distances of r_1 and r_2 from the well have been measured as s_1 and s_2 respectively, for a pumping rate of Q . The transmissivity of the aquifer is equal to

- (A) $\frac{Q}{2\pi} \left(\frac{\ln \frac{r_2}{r_1}}{s_1 - s_2} \right)$ (B) $\frac{Q}{2\pi} \frac{\ln(r_2 - r_1)}{(s_1 - s_2)}$
 (C) $\frac{Q}{2\pi} \ln \left[\frac{r_2/r_1}{s_2/s_1} \right]$ (D) $2\pi Q \frac{r_2 - r_1}{\ln \left(\frac{s_2}{s_1} \right)}$

Question. 32

The range of void ratio between which quick sand condition occurs in cohesion-less granular soil deposits is

- (A) $0.4 - 0.5$ (B) $0.6 - 0.7$
 (C) $0.8 - 0.9$ (D) $1.0 - 1.1$

Question. 33

To provide safety against piping failure, with a factor of safety of 5, what should be the maximum permissible exit gradient for soil with specific gravity of 2.5 and porosity of 0.35 ?

- (A) 0.155 (B) 0.167
(C) 0.195 (D) 0.213

Question. 34

Figure given below shows a smooth vertical gravity retaining wall with cohesionless soil backfill having an angle of internal friction ϕ . In the graphical representation of Rankine's active earth pressure for the retaining wall shown in figure, length OP represents

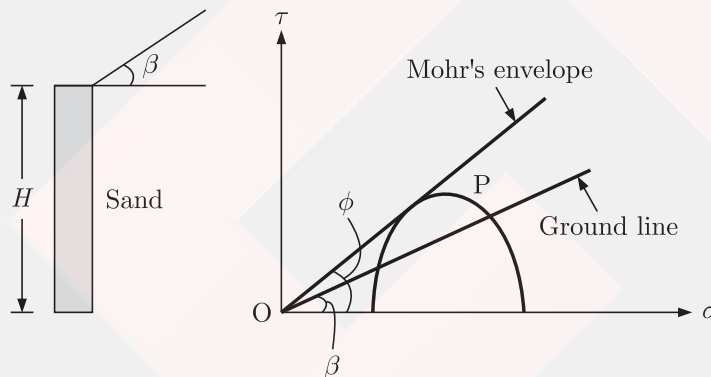

- (A) vertical stress at the base
(B) vertical stress at a height $H/3$ from the base
(C) lateral earth pressure at the base
(D) lateral earth pressure at a height $H/3$ from the base

Question. 35

A sample of saturated cohesionless soil tested in a drained triaxial compression test showed an angle of internal friction of 30° . The deviatoric stress at failure for the sample at a confining pressure of 200 kPa is equal to

- (A) 200 kPa (B) 400 kPa
(C) 600 kPa (D) 800 kPa

Question. 36

List I below gives the possible types of failure for a finite soil slope and List II gives the reasons for these different types of failure. Match the items in List I with the items in List II and select the correct answer from the codes given below the lists :

List I	List II
a. Base failure	1. Soils above and below the toe have same strength
b. Face failure	2. Soil above and toe is comparatively weaker
c. Toe failure	3. Soil above the toe is comparatively stronger

Codes :

	a	b	c
(A)	1	2	3
(B)	2	3	1
(C)	2	1	3
(D)	3	2	1

Question. 37

For the soil profile shown in Figure below, the minimum number of precast concrete piles of 300 mm diameter required of safely carry the load for a given factor of safety of 2.5 (assuming 100% efficiency for the pile group) is equal to

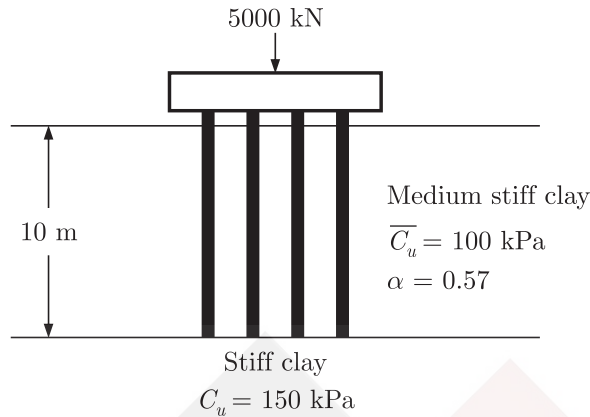

- (A) 10 (B) 15
(C) 20 (D) 25

Question. 38

In a standard proctor test, 1.8 kg of moist soil was filling the mould (volume= 94.4cc) after compaction. A soil sample weighing 23 g was taken from the mould and oven-dried for 24 hours at a temperature of 110°C . Weight of the dry sample was found to be 20 g. Specific gravity of soil solids is $G = 2.7$. The theoretical maximum value of the dry unit weight of the soil at the water content is equal to

- (A) 4.67 kN/m^3 (B) 11.5 kN/m^3
(C) 16.26 kN/m^3 (D) 18.85 kN/m^3

Statement for Linked Answer Questions 39 and 40 :

The average effective overburden pressure on 10 m thick homogeneous saturated clay layer is 150 kPa. Consolidation test on an undisturbed soil sample taken from the clay layer showed that the void ratio decreased from 0.6 to 0.5 by increased the stress intensity from 100 kPa to 300 kPa ($G = 2.65$).

Question. 39

The initial void ratio of the clay layer is

- (A) 0.209 (B) 0.563
(C) 0.746 (D) 1.000

Question. 40

The total consolidation settlement of the clay layer due to the construction of a structure imposing an additional stress intensity of 200 kPa is

- (A) 0.10 m (B) 0.25 m
(C) 0.35 m (D) 0.50 m

Statement for Linked Answer Questions 41 and 42 :

Laboratory sieve analysis was carried out on a soil sample using a complete set of standard IS sieves. Out of 500 g of soil used in the test, 200 g was retained on IS 600 μ sieve, 250 g was retained on IS 500 μ sieve and the remaining 50 g was retained on IS 425 μ sieve.

Question. 41

The coefficient of uniformity of the soil is

- (A) 0.9 (B) 1.0
(C) 1.1 (D) 1.2

Question. 42

The classification of the soil is

- (A) *SP* (B) *SW*
(C) *GP* (D) *GW*

Question. 43

In case of governing equation for calculating wheel load stresses using Westergaard's approach, the following statements are made :

1. Load stresses are inversely proportional to wheel load.
2. Modulus of subgrade reaction is useful for load stress calculation.

- (A) Both statements are TRUE
(B) 1 is TRUE and 2 is FALSE

- (C) Both statements are FALSE
 (D) 1 is FALSE and 2 is TRUE

Question. 44

Name the traffic survey data which is plotted by means of Desire lines.

- (A) Accident (B) Classified volume
 (C) Origin and Destination (D) Speed and Delay

Question. 45

If aggregate size of 50-40 is to be tested for finding out the portion of elongated aggregates using length gauge, the slot length of the gauge should be

- (A) 81 mm (B) 45 mm
 (C) 53 mm (D) 90 mm

Question. 46

Using IRC : 37-1984 “ Guidelines for the Design of Flexible Pavements” and the following data, choose the total thickness of the pavement.

Number of commercial vehicles when construction is completed	2723 Veh/day
Annual growth rate of the traffic	5.0%
Design life of the pavement	10 years
Vehicle damage factor	2.4
CBR value of the subgrade soil	5%

Data for 5% CBR value	
Number of Standard Axles, msa	Total Thickness, mm
20	620
25	640
30	670
40	700

- (A) 620 mm (B) 640 mm

(C) 670 mm

(D) 700 mm

Question. 47

A vehicle moving at 60 kmph on an ascending gradient of a highway has to come to stop position to avoid collision with a stationary object. The ratio of lag to brake distance is 6.5. Considering total reaction time of the driver as 2.5 seconds and the coefficient of longitudinal friction as 0.36, the value of ascending gradient (%) is

(A) 3.3

(B) 4.8

(C) 5.3

(D) 6.8

Question. 48

At an horizontal curve portion of a 4 lane undivided carriageway, a transition curve is to be introduced to attain required superelevation.

The design speed is 60 kmph and radius of the curve is 245 m. Assume length of wheel base of a longest vehicle as 6 m, superelevation as 1 in 150. The length of the transition curve (m) required, if the pavement is rotated about inner edge is

(A) 81.4

(B) 85.0

(C) 91.5

(D) 110.2

Question. 49

For designing a 2-phase fixed type signal at an intersection having North-South and East-West road where only straight ahead traffic is permitted, the following data is available.

Parameter	North	South	East	West
Design Hour Flow (PCU/hr)	1000	700	900	550
Saturation Flow (PCU/hr)	2500	2500	3000	3000

Total time lost per cycle is 12 seconds. The cycle length (seconds) as per Webster's approach is

(A) 67

(B) 77

(C) 87

(D) 91

Question. 50

On an urban road, the free mean speed was measured as 70 kmph and the average spacing between the vehicles under jam condition as 7.0 m. The speed-flow-density equation is given by :

$$U = U_{sf} \left[1 - \frac{k}{k_j} \right] \text{ and } q = Uk$$

Where,

U = space-mean speed (kmph);

U_{sf} = free mean speed (kmph);

k = jam density (veh/km);

q = flow (veh/hr).

The maximum flow (veh/hr) per lane for this condition is equal to

- (A) 2000 (B) 2500
(C) 3000 (D) None of the above

Question. 51

A subgrade soil sample was tested using standard CBR apparatus and the observations are given below.

Load, kg	Penetration, mm
60.5	25
80.5	5.0

Assuming that the load-penetration curve is convex throughout, the CBR value (%) of the sample is

- (A) 6.5 (B) 5.5
(C) 4.4 (D) 3.9

Question. 52

The observed magnetic bearing of a line OE was found to be 185° . It was later discovered that station O had a local attraction of $+1.5^\circ$.

The true bearing of the line OE, considering a magnetic declination of 3.5°E shall be

- (A) 180° (B) 187°
 (C) 190° (D) 193°

Question. 53

A Bench Marck (BM) with Reduced Level (RL) = 155.305 m has been established at the floor of a room. It is required to find out the RL of the underside of roof (R) of the room using Spirit Levelling. The Back Sight (BS) to the BM has been observed as 1.500 m whereas the Fore Sight (FS) to R has been observed as 0.575 m (Staff held inverted). The RL(m) of R will be

- (A) 155.880 (B) 156.230
 (C) 157.380 (D) 157.860

Question. 54

Consider the following figure, which is an extract from a contour map (scale = 1:20,000) of an area. An alignment of a road at a ruling gradient of 4% is to be fixed from the point O and beyond. What should be the radius of the arc with O as the center to get the point of alignment of the next contour on the map ?

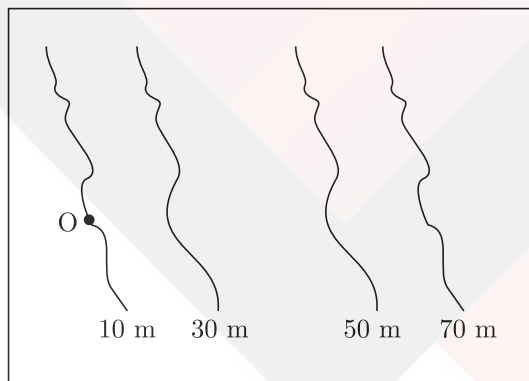

- (A) 0.025 cm (B) 0.25 cm
 (C) 2.5 cm (D) 5.0 cm

Question. 55

In the figure given below, the length PQ (WCB : 30°) and QR (WCB : 45°) respectively up to three places of decimal are

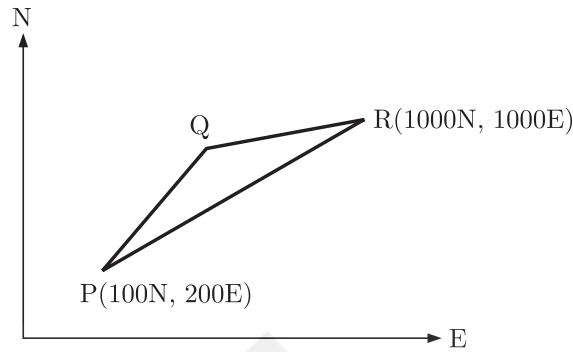

- (A) 273.205,938.186 (B) 273.205,551.815
 (C) 551.815,551.815 (D) 551.815,938.186

Question. 56

During a levelling work along a falling gradient using a Dumpy level and a Staff of 3 m length, following successive readings were taken :

1.785,2.935,0.360,1.320. What will be the correct order of booking these four readings in a level book ? (BS : Back Sight, IS : Intermediate Sight, FS : Fore Sight)

- (A) BS, FS, BS, FS (B) BS, IS, FS, FS
 (C) BS, IS, IS, FS (D) BS, IS, BS, FS

Question. 57

During a 3 hour storm event, it was observed that all abstractions other than infiltration are negligible. The rainfall was idealized as 3 one hour storms of intensity 10 mm/hr, 20 mm/hr and 10 mm/hr respectively and the infiltration was idealized as a Horton curve, $f = 6.8 + 8.7 \exp(-t)$ (f in mm/hr and t in hr) What is the effective rainfall ?

- (A) 10.00 mm (B) 11.33 mm
 (C) 12.43 mm (D) 13.63 mm

Question. 58

In a cultivated area, the soil has porosity of 45% and field capacity of 38%. For a particular crop, the root zone depth is 1.0m, the permanent wilting point is 10% and the consumptive use is 15 mm/d. If the irrigation efficiency is 60%, what should be the frequency of irrigation such that the moisture content does not fall below 50% of the maximum avail-

able moisture ?

- (A) 5d (B) 6d
(C) 9d (D) 15d

Common Data for Questions 59 and 60 :

For a catchment, the S-curve (or S-hydrograph) due to a rainfall of intensity 1 cm/hr is given by $Q = 1 - (1 + t) \exp(-t)$ (t in hr and Q in m^3/s).

Question. 59

What is the area of the catchment ?

- (A) 0.01 km^2 (B) 0.36 km^2
(C) 1.00 km^2 (D) 1.28 km^2

Question. 60

What will be the ordinate of a 2-hour unit hydrograph for this catchment at $t = 3$ hours ?

- (A) $0.13 \text{ m}^3/\text{s}$ (B) $0.20 \text{ m}^3/\text{s}$
(C) $0.27 \text{ m}^3/\text{s}$ (D) $0.54 \text{ m}^3/\text{s}$

Question. 61

If the characteristic strength of concrete f_{ck} is defined as the strength below which not more than 50% of the test results are expected to fall, the expression for f_{ck} in terms of mean strength f_m and standard deviation S would be

- (A) $f_m - 0.1645S$ (B) $f_m - 1.645S$
(C) f_m (D) $f_m + 1.645S$

Question. 62

Assuming concrete below the neutral axis to be cracked, the shear stress across the depth of a singly-reinforced rectangular beam section

- (A) increases parabolically to the neutral axis and then drops suddenly to zero value.

- (B) increases parabolically to the neutral axis and then remains constant over the remaining depth.
- (C) increases linearly to the neutral axis and then remains constant up to the tension steel.
- (D) increases parabolically to the neutral axis and then remains constant up to the tension steel.

Question. 63

As per IS:456-2000, consider the following statements :

1. The modular ratio considered in the working stress method depends on the type of steel used.
2. There is an upper limit on the nominal shear stress in beams (even with shear reinforcement) due to the possibility of crushing of concrete in diagonal compression.
3. A rectangular slab whose length is equal to its width may not be a two-way slab for some support conditions.

The TRUE statements are

- (A) 1 and 2
- (B) 2 and 3
- (C) 1 and 3
- (D) 1, 2 and 3

Question. 64

Consider the following statements :

1. The width-to-thickness ratio limitations of the plate elements under compression in steel members are imposed by IS:800-1984 in order to avoid fabrication difficulties.
2. In a doubly reinforced concrete beam, the strain in compressive reinforcement is higher than the strain in the adjoining concrete.
3. If a cantilever I-section supports slab construction all along its length with sufficient friction between them, the permissible bending stress in compression will be the same as that in tension.

The TRUE statements are

- (A) 1 and 2
- (B) 2 and 3

(C) 1 and 3

(D) 1, 2 and 3

Statement for Linked Answer Questions 65 and 66 :

In the design of beams for the limit state of collapse in flexure as per IS:456-2000, let the maximum strain in concrete be limited to 0.0025 (in place of 0.0035). For this situation, consider a rectangular beam section with breadth as 250 mm, effective depth as 350 mm, area of tension steel as 1500 mm^2 , and the characteristic strength of concrete and steel as 30 MPa and 250 MPa respectively.

Question. 65

The depth of neutral axis for the balanced failure is

(A) 140 mm

(B) 156 mm

(C) 168 mm

(D) 185 mm

Question. 66

At the limiting state of collapse in flexure, the force acting on the compression zone of the section is

(A) 326 kN

(B) 389 kN

(C) 424 kN

(D) 542 kN

Question. 67

Mohr's circle for the state of stress defined by $\begin{bmatrix} 30 & 0 \\ 0 & 30 \end{bmatrix}$ MPa is a circle with

(A) centre at (0, 0) and radius 30 MPa

(B) centre at (0, 0) and radius 60 MPa

(C) centre at (30, 0) and radius 30 MPa

(D) centre at (30, 0) and zero radius

Question. 68

A long shaft of diameter d is subjected to twisting moment T at its ends. The maximum

normal stress acting at its cross-section is equal to

- (A) zero
 (B) $\frac{16T}{\pi d^3}$
 (C) $\frac{32T}{\pi d^3}$
 (D) $\frac{64T}{\pi d^3}$

Question. 69

The buckling load $P = P_{cr}$ for the column AB in figure, as K_T approaches infinity, becomes $\propto \frac{\pi^2 EI}{L^2}$

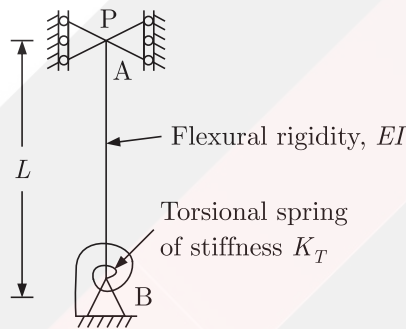

Where α is equal to

- (A) 0.25
 (B) 1.00
 (C) 2.05
 (D) 4.00

Question. 70

A thin-walled long cylindrical tank is inside radius r is subjected simultaneously to internal gas pressure p and axial compressive force F at its ends. In order to produce 'pure shear' state of stress in the wall of the cylinder, F should be equal to

- (A) $p\pi r^2$
 (B) $2p\pi r^2$
 (C) $3p\pi r^2$
 (D) $4p\pi r^2$

Question. 71

Consider the beam AB shown in the figure below. Part AC of the beam is rigid while Part CB has the flexural rigidity EI . Identify the correct combination of deflection at end B and bending moment at end A, respectively

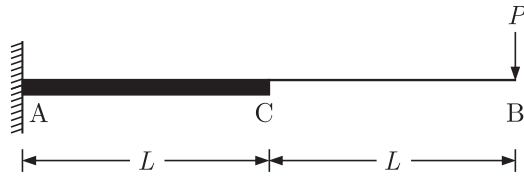

- (A) $\frac{PL^3}{3EI}, 2PL$ (B) $\frac{PL^3}{3EI}, PL$
- (C) $\frac{8PL^3}{3EI}, 2PL$ (D) $\frac{8PL^3}{3EI}, PL$

Question. 72

A simply supported beam AB has the bending moment diagram as shown in the following figure.

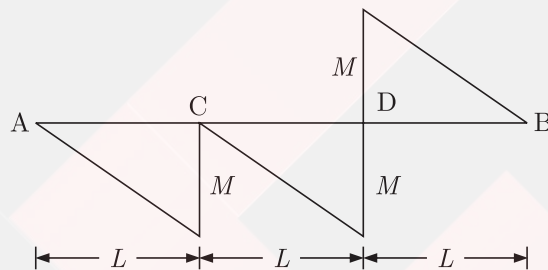

The beam is possibly under the action of following loads

- (A) Couples of M at C and $2M$ at D
- (B) Couples of $2M$ at C and M at D
- (C) Concentrated loads of M/L at C and $2M/L$ at D
- (D) Concentrated load of M/L at C and couple of $2M$ at D

Question. 73

A beam with the cross-section given is subjected to a positive bending moment (causing compression at the top) of 16 kNm acting around the horizontal axis. The tensile force acting on the hatched area of the cross-section is

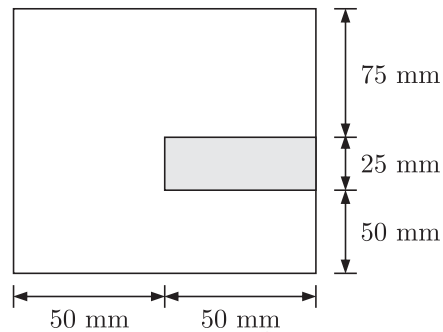

- (A) zero
 (B) 5.9 kN
 (C) 8.9 kN
 (D) 17.8 kN

Question. 74

If a beam of rectangular cross-section is subjected to a vertical shear force V , the shear force carried by the upper one-third of the cross-section is

- (A) zero
 (B) $\frac{7V}{27}$
 (C) $\frac{8V}{27}$
 (D) $\frac{V}{3}$

Question. 75

For the section shown below, second moment of the area about an axis $d/4$ distance above the bottom of the area is

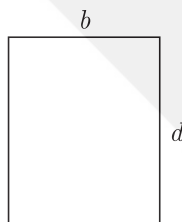

- (A) $\frac{bd^3}{48}$
 (B) $\frac{bd^3}{12}$
 (C) $\frac{7bd^3}{48}$
 (D) $\frac{bd^3}{3}$

Question. 76

I-section of a beam is formed by gluing wooden planks as shown in the figure below. If this beam transmits a constant vertical shear force of 3000 N, the glue at any of the four joint will be subjected to a shear force (in kN per meter length) of

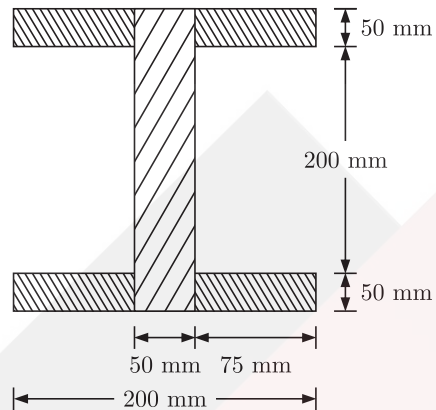

- (A) 3.0
(B) 4.0
(C) 8.0
(D) 10.7

Common data for questions 77 & 78 :

Consider a propped cantilever beam ABC under two loads of magnitude P each as shown in the figure below. Flexural rigidity of the beam is EI .

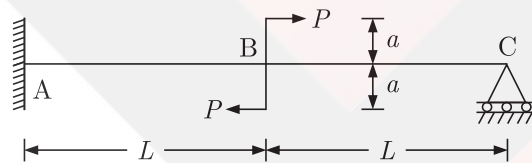
**Question. 77**

The reaction at C is

- (A) $\frac{9Pa}{16L}$ (upwards)
(B) $\frac{9Pa}{16L}$ (downwards)
(C) $\frac{9Pa}{8L}$ (upwards)
(D) $\frac{9Pa}{8L}$ (downwards)

Question. 78

The rotation at B is

- (A) $\frac{5PLa}{16EI}$ (clockwise) (B) $\frac{5PLa}{16EI}$ (anticlockwise)
 (C) $\frac{59PLa}{16EI}$ (clockwise) (D) $\frac{59PLa}{16EI}$ (anticlockwise)

Question. 79

Vertical reaction developed at B in the frame below due to the applied load to 100 kN (with $150,000\text{mm}^2$ cross-sectional area and $3.125 \times 10^9 \text{mm}^4$ moment of inertia for both members) is

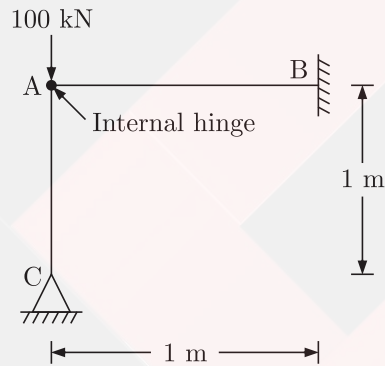

- (A) 5.9 kN (B) 30.2 kN
 (C) 66.3 kN (D) 94.1 kN

Question. 80

Carry-over factor C_{AB} for the beam shown in the figure below is

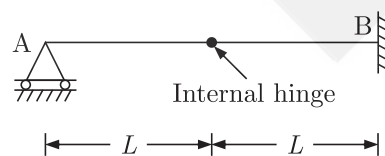

- (A) 1/4 (B) 1/2
 (C) 3/4 (D) 1

Question. 81

Consider the beam ABCD and the influence line as shown below. The influence line pertains to

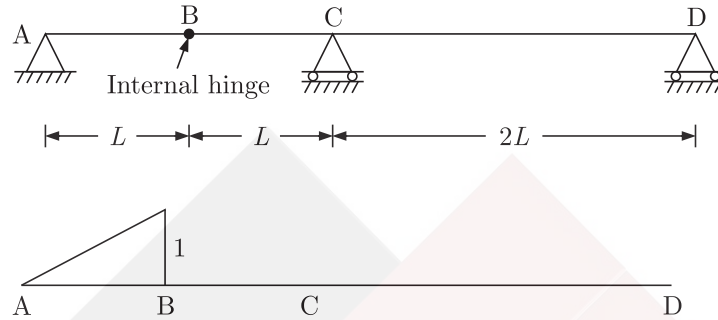

- (A) reaction at A, R_A
- (B) shear force at B, V_B
- (C) shear force on the left of C, V_C^-
- (D) shear force on the right of C, V_C^+
