

**Question. 1**

A steel flat of rectangular section of size  $70 \times 6$  mm is connected to a gusset plate by three bolt each having a shear capacity of 15 kN in holes having diameter 11.5 mm. If the allowable tensile stress in the flat is 150 MPa, the maximum tension that can be applied to the flat is

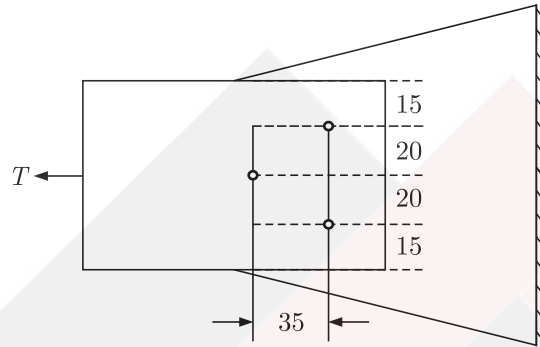

- (A) 42.3 kN  
(B) 52.65 kN  
(C) 59.5 kN  
(D) 63.0 kN

**Question. 2**

A bracket connection is made with four bolts of 10 mm diameter and supports a load of 10 kN at an eccentricity of 100 mm. The maximum force to be resisted by any bolt will be

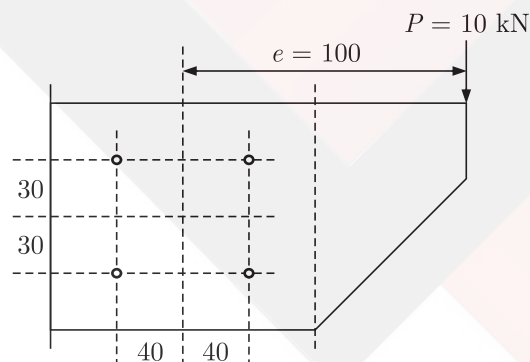

- (A) 5 kN  
(B) 6.5 kN  
(C) 6.8 kN  
(D) 7.16 kN

**Question. 3**

The plastic collapse load  $W_P$  for the propped cantilever supporting two point loads as

shown in fig. in terms of plastic moment capacity,  $W_P$  is given by

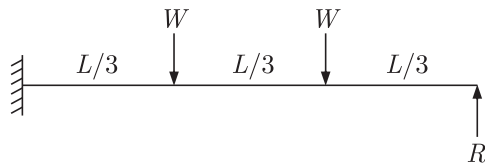

- (A)  $\frac{3M_P}{L}$  (B)  $\frac{4M_P}{L}$   
 (C)  $\frac{5M_P}{L}$  (D)  $\frac{6M_P}{L}$

**Question. 4**

The minimum and the maximum eigen values of the matrix  $\begin{bmatrix} 1 & 1 & 3 \\ 1 & 5 & 1 \\ 3 & 1 & 1 \end{bmatrix}$  are  $-2$  and  $6$ , respectively. What is the other eigen value ?

- (A) 5 (B) 3  
 (C) 1 (D)  $-1$

**Question. 5**

The degree of the differential equation  $\frac{d^2x}{dt^2} + 2x^3 = 0$  is

- (A) 0 (B) 1  
 (C) 2 (D) 3

**Question. 6**

The solution for the differential equation  $\frac{dy}{dx} = x^2 y$  with the condition that  $y = 1$  at  $x = 0$  is

- (A)  $y = e^{\frac{1}{2x}}$  (B)  $\ln(y) = \frac{x^3}{3} + 4$   
 (C)  $\ln(y) = \frac{x^2}{2}$  (D)  $y = e^{\frac{x^3}{3}}$

**Question. 7**

For the values of  $a$  and  $b$  the following simultaneous equations have an infinite number of solutions ?

$$x + y + z = 5; \quad x + 3y + 3z = 9; \quad x + 2y + \alpha z = \beta$$

- (A) 2,7  
(B) 3,8  
(C) 8,3  
(D) 7,2

**Question. 8**

A velocity vector is given as  $\vec{V} = 5xy\vec{i} + 2y^2\vec{j} + 3yz^2\vec{k}$ . The divergence of this velocity vector at (1,1,1) is

- (A) 9  
(B) 10  
(C) 14  
(D) 15

**Question. 9**

A body originally at  $60^\circ\text{C}$  cools down to  $40^\circ\text{C}$  in 15 minutes when kept in air at a temperature  $25^\circ\text{C}$ . What will be the temperature of the body at the end of 30 minutes ?

- (A)  $35.2^\circ\text{C}$   
(B)  $31.5^\circ\text{C}$   
(C)  $28.7^\circ\text{C}$   
(D)  $15^\circ\text{C}$

**Question. 10**

The following equation needs to be numerically solved using the Newton-Raphson method.

$$x^3 + 4x - 9 = 0$$

The iterative equation for this purpose is (k indicates the iteration level)

- (A)  $X_{k+1} = \frac{2X_k^3 + 9}{3X_k^2 + 4}$   
(B)  $X_{k+1} = \frac{3X_k^2 + 4}{2X_k^2 + 9}$   
(C)  $X_{k+1} = X_k - 3X_k^2 + 4$   
(D)  $X_{k+1} = \frac{4X_k^2 + 3}{9X_k^2 + 2}$

**Question. 11**

Evaluate  $\int_0^{\infty} \frac{\sin t}{t} dt$

- (A)  $\pi$  (B)  $\frac{\pi}{2}$   
(C)  $\frac{\pi}{4}$  (D)  $\frac{\pi}{8}$

**Question. 12**

Potential function  $\phi$  is given as  $\phi = x^2 - y^2$ . What will be the stream function ( $\Psi$ ) with the condition  $\Psi = 0$  at  $x = y = 0$  ?

- (A)  $2xy$  (B)  $x^2 + y^2$   
(C)  $x^2 - y^2$  (D)  $2x^2y^2$

**Question. 13**

The inverse of the  $2 \times 2$  matrix  $\begin{bmatrix} 1 & 2 \\ 5 & 7 \end{bmatrix}$  is

- (A)  $\frac{1}{3} \begin{bmatrix} -7 & 2 \\ 5 & -1 \end{bmatrix}$  (B)  $\frac{1}{3} \begin{bmatrix} 7 & 2 \\ 5 & 1 \end{bmatrix}$   
(C)  $\frac{1}{3} \begin{bmatrix} 7 & -2 \\ -5 & 1 \end{bmatrix}$  (D)  $\frac{1}{3} \begin{bmatrix} -7 & -2 \\ -5 & -1 \end{bmatrix}$

**Question. 14**

Given that one root of the equation  $x^3 - 10x^2 + 31x - 30 = 0$  is 5, the other two roots are

- (A) 2 and 3 (B) 2 and 4  
(C) 3 and 4 (D) -2 and -3

**Question. 15**

If the standard deviation of the spot speed of vehicles in a highway is 8.8 kmph and the mean speed of the vehicles is 33 kmph, the coefficient of variation in speed is

- (A) 0.1517 (B) 0.1867  
(C) 0.2666 (C) 0.3446

**Question. 16**

The pressure of hardness in excess of permissible limit causes

- (A) cardio-cascular problems  
(B) skin discolouration  
(C) calcium deficiency  
(D) increased laundry expenses

**Question. 17**

The dispersion of pollutants in atmosphere is maximum when

- (A) environment lapse rate is greater than adiabatic lapse rate  
(B) environment lapse rate is less than adiabatic lapse rate  
(C) environment lapse rate is equal to adiabatic lapse rate  
(D) maximum mixing depth is equal to zero

**Question. 18**

The alkalinity and the hardness of a water sample are 250 mg/L and 350 mg/L as  $\text{CaCO}_3$ , respectively. The water has

- (A) 350 mg/L carbonate hardness and zero non-carbonate hardness  
(B) 250 mg/L carbonate hardness and zero non-carbonate hardness  
(C) 250 mg/L carbonate hardness and 350 mg/L non-carbonate hardness  
(D) 250 mg/L carbonate hardness and 100 mg/L non-carbonate hardness

**Question. 19**

Two electrostatic precipitators (ESPs) are in series. The fractional efficiencies of the upstream and downstream ESPs for size  $d_p$  are 80% and 65%, respectively. What is the overall efficiency of the system for the same  $d_p$  ?

- (A) 100% (B) 93%  
(C) 80% (D) 65%

**Question. 20**

50 g of  $CO_2$  and 25 g of  $CH_4$  are produced from the decomposition of municipal solid waste (MSW) with a formula weight of 120 g. What is the average per capita green house gas production in a city of 1 million people with a MSW production rate of 500 ton/day ?

- (A) 104 g/day (B) 120 g/day  
(C) 208 g/day (D) 313 g/day

**Common Data for Questions 21 and 22 :**

A completely mixed activated sludge process is used to treat a wastewater flow of 1 million litres per day (1 MLD) having a  $BOD_5$  of 200 mg/L. The biomass concentration in the aeration tank is 2000 mg/L and the concentration of the net biomass leaving the system is 50 mg/L. The aeration tank has a volume of 200 m<sup>3</sup>

**Question. 21**

What is the hydraulic retention time of the wastewater in aeration tank ?

- (A) 0.3 h (B) 4.8 h  
(C) 10 h (D) 24 h

**Question. 22**

What is the average time for which the biomass stays in the system ?

- (A) 5 h (B) 8 h  
(C) 2 days (D) 8 days

**Common Data for Questions 23 and 24 :**

A plain sedimentation tank with a length of 20 m, width of 10 m, and a depth of 3 m is used in a water treatment plant to treat 4 million litres of water per day (4 MLD). The av-

average temperature of water is  $20^{\circ}\text{C}$ . The dynamic viscosity of water is  $1.002 \times 10^{-3} \text{ Ns/m}^2$  at  $20^{\circ}\text{C}$ . Density of water is  $998.2 \text{ kg/m}^3$ . Average specific gravity of particles is 2.65.

**Question. 23**

What is the surface overflow rate in the sedimentation tank ?

- (A)  $20 \text{ m}^3/\text{m}^2/\text{day}$                       (B)  $40 \text{ m}^3/\text{m}^2/\text{day}$   
(C)  $67 \text{ m}^3/\text{m}^2/\text{day}$                       (D)  $133 \text{ m}^3/\text{m}^2/\text{day}$

**Question. 24**

What is the minimum diameter of the particle which can be removed with 100% efficiency in the above sedimentation tank ?

- (A)  $11.8 \times 10^{-3} \text{ mm}$                       (B)  $16.0 \times 10^{-3} \text{ mm}$   
(C)  $50 \times 10^{-3} \text{ mm}$                       (D)  $160 \times 10^{-3} \text{ mm}$

**Question. 25**

There is a free overfall at the end of a long open channel. For a given flow rate, the critical depth is less than the normal depth. What gradually varied flow profile will occur in the channel for this flow rate ?

- (A)  $M_1$     (B)  $M_2$   
(C)  $M_3$     (D)  $S_1$

**Question. 26**

At two point 1 and 2 in a pipeline the velocities are  $V$  and  $2V$ , respectively. Both the points are at the same elevation. The fluid density is  $\rho$ . The flow can be assumed to be incompressible, inviscid, steady and irrotational. The difference in pressures  $P_1$  and  $P_2$  at point 1 and 2 is

- (A)  $0.5 \rho V^2$                                       (B)  $1.5 \rho V^2$   
(C)  $2 \rho V^2$                                       (D)  $3 \rho V^2$

**Question. 27**

A horizontal water jet with a velocity of 10 m/s and cross sectional area of 10 mm<sup>2</sup> strikes a flat plate held normal to the flow direction. The density of water is 1000 kg/m<sup>3</sup>. The total force on the plate due to the jet is

- (A) 100 N (B) 10 N  
(C) 1 N (D) 0.1 N

**Question. 28**

A 1:50 scale model of a spillway is to be tested in the laboratory. The discharge in the prototype is 100 kg/m<sup>3</sup>. The discharge to be maintained in the model test is

- (A) 0.05 m<sup>3</sup>/s (B) 0.08 m<sup>3</sup>/s  
(C) 0.57 m<sup>3</sup>/s (D) 5.7 m<sup>3</sup>/s

**Question. 29**

A triangle open channel has a vertex angle of 90° and carries flow at a critical depth of 0.30 m. The discharge in the channel is

- (A) 0.08 m<sup>3</sup>/s (B) 0.11 m<sup>3</sup>/s  
(C) 0.15 m<sup>3</sup>/s (D) 0.2 m<sup>3</sup>/s

**Question. 30**

Flow rate of a fluid (density = 1000 kg/m<sup>3</sup>) in a small diameter tube is 800 mm<sup>3</sup>/s. The length and the diameter of the tube are 2 m and 0.5 mm, respectively. The pressure drop in 2 m length is equal to 2.0 MPa. The viscosity of the fluid is

- (A) 0.025 Ns/m<sup>2</sup> (B) 0.012 Ns/m<sup>2</sup>  
(C) 0.00192 Ns/m<sup>2</sup> (D) 0.00102 Ns/m<sup>2</sup>

**Question. 31**

The flow rate in the rectangular open channel is 2.0 m<sup>3</sup>/s per metre width. The channel bed slope is 0.002. The slope of the channel is classified as

- (A) Critical (B) Horizontal



- (C) Mild (D) Steep

**Statement for Linked Questions 32 and 33 :**

A rectangular open channel needs to be designed to carry a flow of  $2.0 \text{ m}^3/\text{s}$  under uniform flow conditions. The Manning's roughness coefficient is 0.018. The channel should be such that the flow depth is equal to half width, and the Froude number is equal to 0.5.

**Question. 32**

The bed slope of the channel to be provided is

- (A) 0.0012 (B) 0.0021  
(C) 0.0025 (D) 0.0052

**Question. 33**

Keeping the width, flow depth and roughness the same, if the bed slope of the above channel is double, the average boundary shear stress under uniform flow conditions is

- (A)  $5.6 \text{ N/m}^2$  (B)  $10.8 \text{ N/m}^2$   
(C)  $12.3 \text{ N/m}^2$  (D)  $17.2 \text{ N/m}^2$

**Question. 34**

The necessary and sufficient condition for a surface to be called as a 'free surface' is

- (A) no stress should be acting on it  
(B) tensile stress acting on it must be zero  
(C) shear stress acting on it must be zero  
(D) no print on it should be under any stress

**Question. 35**

A channel with a mild slope is followed by a horizontal channel and then by a steep channel. What gradually varied flow profiles will occur ?

- (A)  $M_1, H_1, S_1$  (B)  $M_2, H_2, S_2$

(C)  $M_1, H_2, S_3$ (D)  $M_1, H_2, S_2$ **Question. 36**

Identify the FALSE statement from the following. The specific speed of the pump increases with

- (A) increase in shaft speed
- (B) increase in discharge
- (C) decrease in gravitational acceleration
- (D) increase in head

**Question. 37**

A clay soil sample is tested in a triaxial apparatus in consolidated-drained conditions at a cell pressure of  $100 \text{ kN/m}^2$ . What will be the pore water pressure at a deviator stress of  $40 \text{ kN/m}^2$  ?

- (A) 0
- (B)  $20 \text{ kN/m}^2$
- (C)  $40 \text{ kN/m}^2$
- (D)  $60 \text{ kN/m}^2$

**Question. 38**

The number of blows observed in a Standard Penetration Test (SPT) for different penetration depths are given as follows :

Penetration of sampler	Number of blows
0 - 150 mm	6
150 - 300 mm	8
300 - 450 mm	10

The observed  $N$  value is

- (A) 8
- (B) 14
- (C) 18
- (D) 24

**Question. 39**

The vertical stress at some depth below the corner of a  $2\text{ m} \times 3\text{ m}$  rectangular footing due to a certain load intensity is  $100\text{ kN/m}^2$ . What will be the vertical stress in  $\text{kN/m}^2$  below the centre of a  $4\text{ m} \times 6\text{ m}$  rectangular footing at the same depth and same load intensity ?

- (A) 25 (B) 100  
(C) 200 (D) 400

**Question. 40**

Sieve analysis on a dry soil sample of mass  $1000\text{ g}$  showed that  $980\text{ g}$  and  $270\text{ g}$  of soil pass through  $4.75\text{ mm}$  and  $0.075\text{ mm}$  sieve, respectively. The liquid limit and plastic limits of the soil fraction passing through  $425\text{ }\mu$  sieves are  $40\%$  and  $18\%$ , respectively. The soil may be classified as

- (A) *SC* (B) *MI*  
(C) *CI* (D) *SM*

**Question. 41**

The water content of a saturated soil and the specific gravity of soil solids were found to be  $30\%$  and  $2.70$ , respectively. Assuming the unit weight of water to be  $10\text{ kN/m}^3$ , the saturated unit weight  $\text{kN/m}^3$  and the void ratio of the soil are

- (A)  $19.4, 0.81$  (B)  $18.5, 0.30$   
(C)  $19.4, 0.45$  (D)  $18.5, 0.45$

**Question. 42**

The factor of safety of an infinite soil slope shown in the figure having the properties  $C = 0$ ,  $\phi = 35^\circ$ ,  $\gamma_{\text{dry}} = 16\text{ kN/m}^3$  and  $\gamma_{\text{sat}} = 20\text{ kN/m}^3$  is approximately equal to

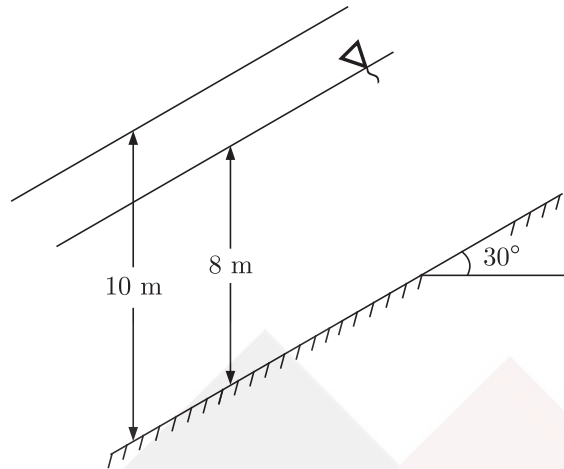

- (A) 0.70                      (B) 0.80  
 (C) 1.00                      (D) 1.20

**Question. 43**

Match List I with List II and select the correct answer using the codes given below the lists :

**List I**

- Constant head permeability test
- Consolidation test
- Pycnometer test
- Negative skin friction

**List II**

- Pile foundation
- Specific gravity
- Clay soil
- Sand

Codes :

- |     | a | b | c | d |
|-----|---|---|---|---|
| (A) | 4 | 3 | 2 | 1 |
| (B) | 4 | 2 | 3 | 1 |
| (C) | 3 | 4 | 2 | 1 |

(D) 4 1 2 3

**Question. 44**

The bearing capacity of a rectangular footing of plan dimensions  $1.5 \text{ m} \times 3 \text{ m}$  resting on the surface of a sand deposit was estimated as  $600 \text{ kN/m}^2$  when the water table is far below the base of the footing. The bearing capacities in  $\text{kN/m}^2$  when the water level rises to depths of 3 m, 1.5 m and 0.5 below the base of the footing are

- (A) 600, 600, 400 (B) 600, 450, 350  
(C) 600, 500, 250 (D) 600, 400, 250

**Question. 45**

What is the ultimate capacity in kN of the pile group shown in the figure assuming the group to fail as a single block ?

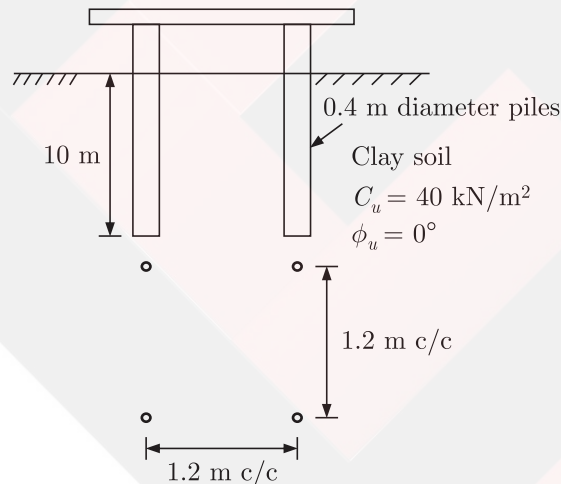

- (A) 921.6 (B) 1177.6  
(C) 2438.6 (D) 2481.6

**Common Data for Questions 46 and 47 :**

Water is flowing through the permeability apparatus shown in the figure. The coefficient of permeability of the soil is ' $k$ ' m/s and the porosity of the soil sample is 0.50.

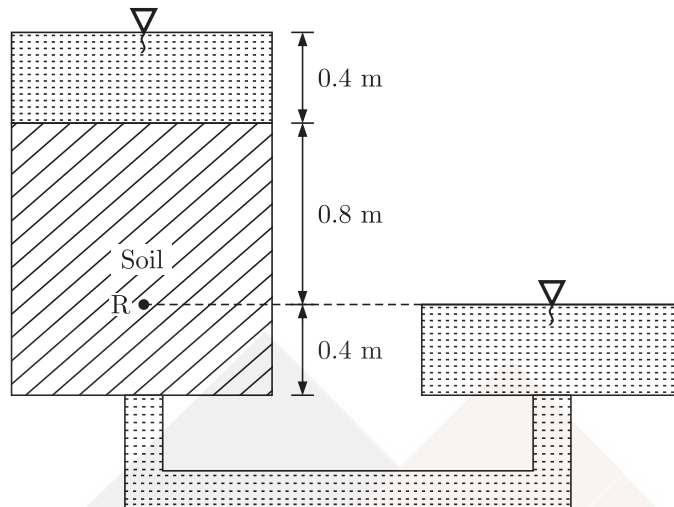
**Question. 46**

The total head, elevation head and pressure head in metres of water at the point  $R$  shown in the figure are

- (A) 0.8, 0.4, 0.4  
 (B) 1.2, 0.4, 0.8  
 (C) 0.4, 0, 0.4  
 (D) 1.6, 0.4, 1.2

**Question. 47**

What are the discharge velocity and seepage velocity through the soil sample ?

- (A)  $k, 2k$   
 (B)  $\frac{2}{3}k, \frac{4}{3}k$   
 (C)  $2k, k$   
 (D)  $\frac{4}{3}k, \frac{2}{3}k$

**Statement for Linked Answer Questions 48 and 49 :**

The ground conditions at a site are as shown in the figure. The water table at the site which was initially at a depth of 5 m below the ground level got permanently lowered to a depth of 15 m below the ground level due to pumping of water over a few years. Assume the following data :

- I unit weight of water = 10 kN/m<sup>3</sup>  
 II unit weight of sand above water table = 18 kN/m<sup>3</sup>

III unit weight of sand and clay below the water table =  $20 \text{ kN/m}^3$

IV coefficient of volume compressibility =  $0.25 \text{ m}^2/\text{MN}$

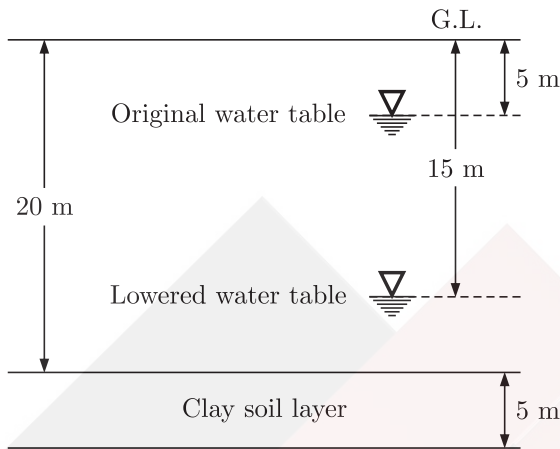

**Question. 48**

What is the change in the effective stress in  $\text{kN/m}^2$  at mid-depth of the clay layer due to the lowering of the water table ?

- (A) 0 (B) 20  
(C) 80 (D) 100

**Question. 49**

What is the compression of the clay layer in mm due to the lowering of the water table ?

- (A) 125 (B) 100  
(C) 25 (D) 0

**Question. 50**

The consistency and flow resistance of bitumen can be determined from which of the following ?

- (A) Ductility test (B) Penetration test  
(C) Softening point test (D) Viscosity test

**Question. 51**

If a two-lane National Highway and a two-lane State Highway intersect at right angles, the number of potential conflict point at the intersection, assuming that both the roads are two-way is

- (A) 11 (B) 17  
(C) 24 (D) 32

**Question. 52**

In signal design as per Indian Roads Congress specifications, if the sum of the ratios of normal flows to saturation flow of two directional traffic is 0.50 and the total lost time per cycle is 10 seconds, the optimum cycle length in seconds is

- (A) 100 (B) 80  
(C) 60 (D) 40

**Question. 53**

The extra widening required for a two-lane National Highway at a horizontal curve of 300 m radius, considering a wheel base of 8 m and a design speed of 100 kmph is

- (A) 0.42 m (B) 0.62 m  
(C) 0.82 m (D) 0.92 m

**Question. 54**

While designing a hill road with a ruling gradient of 6%, if a sharp horizontal curve of 50 m radius is encountered, the compensated gradient at the curve as per the Indian Roads Congress specifications should be

- (A) 4.4% (B) 4.75%  
(C) 5.0% (D) 5.25%

**Question. 55**

The design speed on a road is 60kmph. Assuming the driver reaction time of 2.5 seconds and coefficient of friction of pavement surface as 0.35, the required stopping distance for two-way traffic on a single lane road is



- (A) 82.1 m (B) 102.4 m  
(C) 164.2 m (D) 186.4 m

**Question. 56**

The width of the expansion joint is 20 mm in a cement concrete pavement. The paying temperature is  $20^{\circ}\text{C}$  and the maximum slab temperature in summer is  $60^{\circ}\text{C}$ . The coefficient of the thermal expansion of concrete is  $10 \times 10^{-6} \text{ mm/mm/}^{\circ}\text{C}$  and the joint filler compresses up to 50% of the thickness. The spacing between expansion joints should be

- (A) 20 m (B) 25 m  
(C) 30 m (D) 40 m

**Question. 57**

The following data pertains to the number of commercial vehicles per day for the design of a flexible pavement for a national highway as per IRC : 37-1984 :

Type of commercial vehicle	Number of vehicle per day considering the number of lanes	Vehicle Damage Factor
Two axle trucks	2000	5
Tandem axle trucks	200	6

Assuming a traffic growth factor of 7.5% per annum for both the types of vehicles, the cumulative number of standard axle load repetitions (in million) for a design life of ten years is

- (A) 44.6 (B) 57.8  
(C) 62.4 (D) 78.7

**Question. 58**

Match List-I (Test) with the List-II (Property) and select the correct answers using the codes given below the lists :

**List-I**

- a. Crushing test
- b. Los Angles abrasion test
- c. Soundness test
- d. Angularity test

**List-II**

1. Hardness
2. Weathering
3. Shape
4. Strength

Codes :

	a	b	c	d
(A)	2	1	4	3
(B)	4	2	3	1
(C)	3	2	1	4
(D)	4	1	2	3

**Question. 59**

The plan of a map was photo copied to a reduced size such that a line originally 100 mm, measures 90 mm. The original scale of the plan was 1 : 1000. The revised scale is

- |              |              |
|--------------|--------------|
| (A) 1 : 900  | (B) 1 : 1111 |
| (C) 1 : 1121 | (D) 1 : 1221 |

**Question. 60**

The following tables gives data of consecutive coordinates in respect of a closed theodolite traverse PQRSP.

Station	Northing, m	Southing, m	Easting, m	Westing, m
P	400.75			300.5

Q	100.25		199.25	
R		199.0	399.75	
S		300.0		200.5

The magnitude and direction of error of closure in whole circle bearing are.

- (A) 2.0 m and  $45^\circ$  (B) 2.0 m and  $315^\circ$   
 (C) 2.82 m and  $315^\circ$  (D) 3.42 m and  $45^\circ$

**Question. 61**

The following measurements were made during testing a levelling instrument.

Instrument at	Staff reading at	
	$P_1$	$Q_1$
P	2.800 m	1.700 m
Q	2.700 m	1.800 m

$P_1$  is close to P and  $Q_1$  is close to Q. If the reduced level of station P is 100.000 m, the reduced level of station Q is

- (A) 99.000 m (B) 100.000 m  
 (C) 101.000 m (D) 102.000 m

**Question. 62**

Two straight lines intersect at an angle of  $60^\circ$ . The radius of a curve joining the two straight lines is 600 m. The length of long chord and mid-ordinate in metres of the curve are

- (A) 80.4, 600.0 (B) 600.0, 80.4  
 (C) 600.0, 39.89 (D) 49.89, 300.0

**Question. 63**

The magnetic bearing of a line AB is  $S 45^\circ E$  and the declination is  $5^\circ$  west. The true bearing of the line AB is

- (A) S  $45^\circ$  E (B) S  $40^\circ$  E  
(C) S  $50^\circ$  E (D) S  $50^\circ$  W

**Question. 64**

The consumptive use of water for a crop during a particular stage of growth is 2.0 mm/day. The maximum depth of available water in the root zone is 60 mm. Irrigation is required when the amount of available water is 50% of the maximum available water in the root zone. Frequency of irrigation should be

- (A) 10 days (B) 15 days  
(C) 20 days (D) 25 days

**Question. 65**

As per the Lacey's method for design of alluvial channels, identify the TRUE statement from the following :

- (A) Wetted perimeter increases with an increase in design discharge.  
(B) Hydraulic radius increases with an increase in slit factor.  
(C) Wetted perimeter decreases with an increase in design discharge.  
(D) Wetted perimeter increases with an increase in slit factor.

**Question. 66**

The culturable command area for a distributed channel is 20,000 hectares. Wheat is grown in the entire area and the intensity of irrigation is 50%. The kor period for wheat is 30 days and the kor water depth is 120 mm. The outlet discharge for the distributary should be

- (A)  $2.85 \text{ m}^3/\text{s}$  (B)  $3.21 \text{ m}^3/\text{s}$   
(C)  $4.63 \text{ m}^3/\text{s}$  (D)  $5.23 \text{ m}^3/\text{s}$

**Question. 67**

An isolated 4-hour storm occurred over a catchment as follows :

Time	1 <sup>st</sup> hr	2 <sup>nd</sup> hr	3 <sup>rd</sup> hr	4 <sup>th</sup> hr
------	--------------------	--------------------	--------------------	--------------------

Rainfall (mm)	9	28	12	7
---------------	---	----	----	---

The  $\phi$  index for the catchment is 10 mm/h. The estimated runoff depth from the catchment due to the above storm is

- (A) 10 mm (B) 16 mm  
(C) 20 mm (D) 23 mm

**Common Data for Questions 68 and 69 :**

Ordinates of a 1-hour unity hydrograph at 1 hour intervals, starting from time  $t = 0$  are 0, 2, 6, 4, 2, 1 and 0  $\text{m}^3/\text{s}$

**Question. 68**

Catchment area represented by this unit hydrograph is

- (A) 1.0  $\text{km}^2$  (B) 2.0  $\text{km}^2$   
(C) 3.2  $\text{km}^2$  (D) 5.4  $\text{km}^2$

**Question. 69**

Ordinate of a 3-hour unit hydrograph for the catchment at  $t = 3$  hours is

- (A) 2.0  $\text{m}^3/\text{s}$  (B) 3.0  $\text{m}^3/\text{s}$   
(C) 4.0  $\text{m}^3/\text{s}$  (D) 5.0  $\text{m}^3/\text{s}$

**Question. 70**

Consider the following statements :

1. The compressive strength of concrete decreases with increase in water-cement ratio of the concrete mix
2. Water is added to the concrete mix for hydration of cement and workability.
3. Creep and shrinkage of concrete are independent of the water-cement ratio in the concrete mix.

The TRUE statements are

- (A) 1 and 2                                  (B) 1, 2 and 3  
(C) 2 and 3                                  (D) only 2

**Question. 71**

The percentage loss of prestress due to anchorage slip of 3 mm in a concrete beam of length 30 m which is post-tensioned by a tendon with an initial stress of  $1200 \text{ N/mm}^2$  and modulus of elasticity equal to  $2.1 \times 10^5 \text{ N/mm}^2$  is

- (A) 0.0175                                  (B) 0.175  
(C) 1.75                                      (D) 17.5

**Question. 72**

A concrete beam of rectangular cross-section of size 120 mm (width) and 200 mm (depth) is prestressed by a straight tendon to an effective force of 150 kN at an eccentricity of 20 mm (below the centroidal axis in the depth direction). The stresses at the top and bottom fibres of the section are

- (A)  $2.5 \text{ N/mm}^2$  (compression),  $10 \text{ N/mm}^2$  (compression)  
(B)  $10 \text{ N/mm}^2$  (tension),  $2.5 \text{ N/mm}^2$  (compression)  
(C)  $3.75 \text{ N/mm}^2$  (tension),  $3.75 \text{ N/mm}^2$  (compression)  
(D)  $2.75 \text{ N/mm}^2$  (compression),  $3.75 \text{ N/mm}^2$  (compression)

**Question. 73**

Consider the following statements :

1. Modulus of elasticity of concrete increases with increase in compressive strength of concrete.
2. Brittleness of concrete increases with decrease in compressive strength of concrete.
3. Shear strength of concrete increase with increase in compressive strength of concrete.

The TRUE statements are

- (A) 2 and 3                                  (B) 1, 2 and 3

(C) 1 and 2

(D) 1 and 3

**Common Data for Questions 74 and 75 :**

A single reinforced rectangular concrete beam has a width of 150 mm and an effective depth of 330 mm. The characteristic compressive strength of concrete is 20 MPa and the characteristic tensile strength of steel is 415 MPa. Adopt the stress block for concrete as given in IS : 456-2000 and take limiting value of depth of depth of neutral axis as 0.48 times the effective depth of the beam.

**Question. 74**

The limiting value of the moment of resistance of the beam in kNm is

(A) 0.14

(B) 0.45

(C) 45.08

(D) 156.82

**Question. 75**

The limiting area of tension steel in  $\text{mm}^2$  is

(A) 473.9

(B) 412.3

(C) 373.9

(D) 312.3

**Question. 76**

An axially loaded bar is subjected to a normal stress of 173 MPa. The stress in the bar is

(A) 75 MPa

(B) 86.5 MPa

(C) 100 MPa

(D) 122.3 MPa

**Question. 77**

A steel column, pinned at both end, has a buckling load of 200 kN. If the column is restrained against lateral movement at its mid-height, its buckling load will be

(A) 200 kN

(B) 283 kN

(C) 400 kN

(D) 800 kN

**Question. 78**

For an isotropic material, the relationship between the Young's modulus ( $E$ ), shear modulus ( $G$ ) and Poisson's ratio ( $\mu$ ) is given by

$$(A) G = \frac{E}{2(1 + \mu)}$$

$$(B) E = \frac{E}{2(1 + \mu)}$$

$$(C) G = \frac{E}{(1 + 2\mu)}$$

$$(D) G = \frac{E}{2(1 - 2\mu)}$$

**Question. 79**

A metal bar of length 100 mm is inserted between two rigid supports and its temperature is increased by  $10^\circ\text{C}$ . If the coefficient of thermal expansion is  $12 \times 10^{-6}$  per  $^\circ\text{C}$  and the Young's modulus is  $2 \times 10^5$  MPa, the stress in the bar is

(A) zero

(B) 12 MPa

(C) 24 MPa

(D) 2400 MPa

**Question. 80**

A rigid bar is suspended by three rods made of the same material as shown in the figure. The area and length of the central rod are  $3A$  and  $L$ , respectively while that of the two outer rods are  $2A$  and  $2L$ , respectively. If a downward force of 50 kN is applied to the rigid bar, the forces in the central and each of the outer rods will be

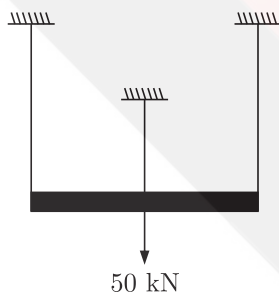

(A) 16.67 kN each

(B) 30 kN and 15 kN

(C) 30 kN and 10 kN

(D) 21.4 kN and 14.3 kN

**Question. 81**

The maximum and minimum shear stresses in a hollow circular shaft of outer diameter 20



mm and thickness 2 mm, subjected to a torque of 92.7 Nm will be

- (A) 59 MPa and 47.2 MPa                      (B) 100 MPa and 80 MPa  
(C) 118 MPa and 160 MPa                      (D) 200 MPa and 160 MPa

**Question. 82**

The shear stress at the neutral axis in a beam of triangular section with a base of 40 mm and height 20 mm, subjected to a shear force of 3 kN is

- (A) 3 MPa    (B) 6 MPa  
(C) 10 MPa    (D) 20 MPa

**Question. 83**

$U_1$  and  $U_2$  are the strain energies stored in a prismatic bar due to axial tensile forces  $P_1$  and  $P_2$ , respectively. The strain energy  $U$  stored in the same bar due to combined action of  $P_1$  and  $P_2$  will be

- (A)  $U = U_1 + U_2$                                       (B)  $U = U_1 U_2$   
(C)  $U < U_1 + U_2$                                       (D)  $U > U_1 + U_2$

**Question. 84**

The stiffness coefficient  $k_{ij}$  indicates

- (A) force at  $i$  due to a unit deformation at  $j$   
(B) deformation at  $j$  due to a unit force at  $i$   
(C) deformation at  $i$  due to a unit force at  $j$   
(D) force at  $j$  due to a unit deformation at  $i$

**Question. 85**

The right triangular truss is made of members having equal cross sectional area of  $1550 \text{ mm}^2$  and Young's modulus of  $2 \times 10^5 \text{ MPa}$ . The horizontal deflection of the joint Q is

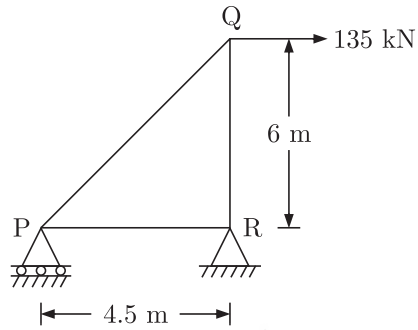

- (A) 2.47 mm  
 (B) 10.25 mm  
 (C) 14.31 mm  
 (D) 15.68 mm

**Question. 86**

The influence line diagram (ILD) shown is for the member

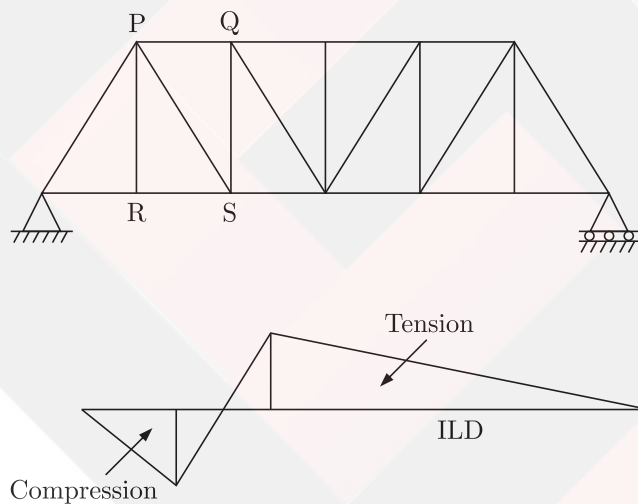

- (A) PS  
 (B) RS  
 (C) PQ  
 (D) QS

**Common Data for Questions 87 & 88:**

A two span continuous beam having equal spans each of length  $L$  is subjected to a uniformly distributed load  $w$  per unit length. The beam has constant flexural rigidity.

**Question. 87**

The reaction at the middle support is

(A)  $wL$  (B)  $\frac{5wL}{2}$

(C)  $\frac{5wL}{4}$  (D)  $\frac{5wL}{8}$

**Question. 88**

The bending moment at the middle support is

(A)  $\frac{wL^2}{4}$  (B)  $\frac{wL^2}{8}$

(C)  $\frac{wL^2}{12}$  (D)  $\frac{wL^2}{16}$

\*\*\*\*\*