

**Question. 1**

In the theory of plastic bending of beams, the ratio of plastic moment to yield moment is called

- (A) shape factor (B) plastic section modulus  
(C) modulus of resilience (D) rigidity modulus

**Question. 2**

The square root of the ratio of moment of inertia of the cross-section to its cross-sectional area is called

- (A) second moment of area (B) slenderness ratio  
(C) section modulus (D) radius of gyration

**Question. 3**

A 12 mm thick plate is connected to two 8 mm thick plates, on either side through a 16 mm diameter power driven field rivet as shown in the figure below. Assuming permissible shear stress as 90 MPa and permissible bearing stress as 270 MPa in the rivet, the rivet value of the joint is

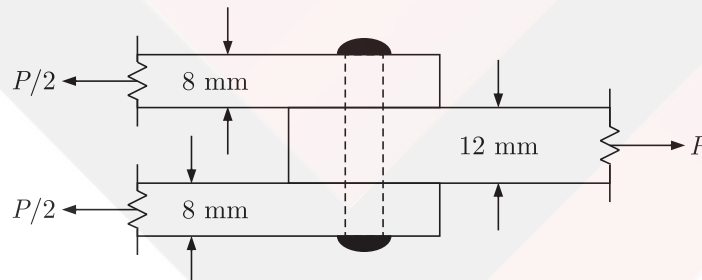

- (A) 56.70 kN (B) 43.29 kN  
(C) 36.19 kN (D) 21.65 kN

**Question. 4**

Consider the following statements for a compression member:

1. The elastic critical stress in compression increases with decrease in slenderness ratio
2. The effective length depends on the boundary conditions at its ends.



**Question. 9**

The value of the integral  $\int_C \frac{\cos(2\pi z)}{(2z-1)(z-3)} dz$  ( where C is a closed curve given by  $|z|=1$  ) is

- (A)  $\pi i$  (B)  $\frac{\pi i}{5}$   
(C)  $\frac{2\pi i}{5}$  (D)  $\pi i$

**Question. 10**

Solution of the differential equation  $3y \frac{dy}{dx} + 2x = 0$  represents a family of

- (A) ellipses (B) circles  
(C) parabolas (D) hyperbolas

**Question. 11**

Laplace transform for the function  $f(x) = \cosh(ax)$  is

- (A)  $\frac{a}{s^2 - a^2}$  (B)  $\frac{s}{s^2 - a^2}$   
(C)  $\frac{a}{s^2 + a^2}$  (D)  $\frac{s}{s^2 + a^2}$

**Question. 12**

In the solution of the following set of linear equations by Gauss elimination using partial pivoting  $5x + y + 2z = 34$ ;  $4y - 3z = 12$ ; and  $10 - 2y + z = -4$ ; the pivots for elimination of  $x$  and  $y$  are

- (A) 10 and 4 (B) 10 and 2  
(C) 5 and 4 (D) 5 and -4

**Question. 13**

The standard normal probability function can be approximated as

$$F(x_N) = \frac{1}{1 + \exp(-1.7255x_N |x_N|^{0.12})}$$

where  $x_N$  = standard normal deviate. If mean and standard deviation of annual precipitation are 102 cm and 27 cm respectively, the probability that the annual precipitation will be between 90 cm and 102 cm is

- (A) 66.7% (B) 50.0%  
(C) 33.3% (D) 16.7%

**Question. 14**

The reference pressure used in the determination of sound pressure level is

- (A) 20  $\mu$ Pa (B) 20 dB  
(C) 10  $\mu$ Pa (D) 10 dB

**Question. 15**

Particulate matter (fly ash) carried in effluent gases from the furnaces burning fossil fuels are better removed by

- (A) Cotton bag house filter  
(B) Electrostatic precipitator (ESP)  
(C) Cyclone  
(D) Wet scrubber

**Question. 16**

Match List-I with List-II and select the correct answer by using the codes given below the lists :

**List-I**

- a. Coriolis effect  
b. Fumigation  
c. Ozone layer  
d. Maximum mixing depth (mixing height)

**List-II**

1. Rotation of earth
2. Lapse rate and vertical temperature profile
3. Inversion
4. Dobson

**Codes :**

	a	b	c	d
(A)	2	1	4	3
(B)	2	1	3	4
(C)	1	3	2	4
(D)	1	3	4	2

**Question. 17**

A horizontal flow primary clarifier treats wastewater in which 10%, 60% and 30% of particles have settling velocities of 0.1 mm/s, 0.2 mm/s and 0.1 mm/s respectively. What would be the total percentage of particles removed if clarifier operates at a Surface Overflow Rate (SOR) of  $43.2 \text{ m}^3/\text{m}^2\text{d}$  ?

- (A) 43% (B) 56%  
(C) 86% (D) 100%

**Question. 18**

An aerobic reactor receives wastewater at a flow rate of  $500 \text{ m}^3/\text{d}$  having a COD of 2000 mg/L. The effluent COD is 400 mg/L. Assuming that wastewater contains 80% biodegradable waste, the daily volume of methane produced by the reactor is

- (A)  $0.224 \text{ m}^3$  (B)  $0.280 \text{ m}^3$   
(C)  $224 \text{ m}^3$  (D)  $280 \text{ m}^3$

**Question. 19**

Match List-I with List-II and select the correct answer using the codes given below the lists :

<b>List-I</b>	<b>List-II</b>
a. Grit chamber	1. Zone settling
b. Secondary settling tank	2. Stoke's law
c. Activated sludge process	3. Aerobic
d. Trickling filter	4. Contact stabilization

**Codes :**

	a	b	c	d
(A)	1	2	3	4
(B)	2	1	3	4
(C)	1	2	4	3
(D)	2	1	4	3

**Common Data for Questions 20 and 21 :**

Following chemical species were reported for water sample from a well :

Species	Concentration (milli equivalent/L)
Chloride ( $\text{Cl}^-$ )	15
Sulphate ( $\text{SO}_4^{2-}$ )	15
Carbonate ( $\text{CO}_3^{2-}$ )	05
Bicarbonate ( $\text{HCO}_3^-$ )	30
Calcium ( $\text{Ca}^{2+}$ )	12
Magnesium ( $\text{Mg}^{2+}$ )	18
pH	8.5

**Question. 20**

Total hardness in mg/L as  $\text{CaCO}_3$  is

- (A) 1500 (B) 2000  
(C) 3000 (D) 5000

**Question. 21**

Alkalinity present in the water in mg/L as  $\text{CaCO}_3$  is

- (A) 250 (B) 1500  
(C) 1750 (D) 5000

**Question. 22**

Direct step method of computation for gradually varied flow is

- (A) applicable to non-prismatic channels  
(B) applicable to prismatic channels  
(C) applicable to both prismatic and non-prismatic channels  
(D) not applicable to both prismatic and non-prismatic channels

**Question. 23**

Water flows through a 100 mm diameter pipe with a velocity of 0.015 m/sec. If the kinematic viscosity of water is  $1.13 \times 10^{-6} \text{ m}^2/\text{sec}$ , the friction factor of the pipe material is

- (A) 0.0015 (B) 0.032

(C) 0.037

(D) 0.048

**Question. 24**

A rectangular open channel of width 4.5 m is carrying a discharge of  $100 \text{ m}^3/\text{sec}$ . The critical depth of the channel is

(A) 7.09 m

(B) 17.0 m

(C) 2.16 m

(D) 1.31 m

**Question. 25**

A rectangular open channel of width 4.5 m is carrying a discharge of  $100 \text{ m}^3/\text{sec}$ . The critical depth of the channel is

(A) 7.09 m

(B) 3.69 m

(C) 2.16 m

(D) 1.31 m

**Question. 26**

Water ( $\gamma_w = 9.879 \text{ kN/m}^3$ ) flows with a flow rate of  $0.3 \text{ m}^3/\text{sec}$  through a pipe AB of 10 m length and of uniform cross-section. The end B is above end A and the pipe makes an angle of  $30^\circ$  to the horizontal. For a pressure of  $12 \text{ N/m}^2$  at the end B, the corresponding pressure at the end A is

(A)  $12.0 \text{ kN/m}^2$ (B)  $17.0 \text{ kN/m}^2$ (C)  $56.4 \text{ kN/m}^2$ (D)  $61.4 \text{ kN/m}^2$ **Question. 27**

Deposit with flocculated structure is formed when

(A) clay particles settle on sea bed

(B) clay particles settle on fresh water lake bed

(C) sand particles settle on river bed

(D) sand particles on sea bed



**Question. 28**

Dilatancy correction is required when a strata is

- (A) cohesive and saturated and also has  $N$  value of  $SPT > 15$
- (B) saturated silt/fine sand and  $N$  value of  $SPT < 15$  after the overburden correction
- (C) saturated silt/fine sand and  $N$  value of  $SPT > 15$  after the overburden correction
- (D) coarse sand under dry condition and  $N$  value of  $SPT < 10$  after the overburden correction

**Question. 29**

A precast concrete pile is driven with a 50 kN hammer railing through a height of 1.0 m with an efficiency of 0.6. The set value observed is 4 mm per below and the combined temporary compression of the pile, cushion and the ground is 6 mm. As per Modified Hiley Formula, the ultimate resistance of the pile is

- (A) 3000 kN
- (B) 4285.7 kN
- (C) 8333 kN
- (D) 11905 kN

**Question. 30**

The relationship among specific yield ( $S_y$ ), specific retention ( $S_r$ ) and porosity ( $\eta$ ) of an aquifer is

- (A)  $S_y = S_r + \eta$
- (B)  $S_y = S_r - \eta$
- (C)  $S_y = \eta - S_r$
- (D)  $S_y = S_r + 2\eta$

**Question. 31**

The laboratory test results of a soil sample are given below :

Percentage finer than 4.75 mm = 60

Percentage finer than 0.075 mm = 30

Liquid Limit = 35%

Plastic Limit 27%

The soil classification is

- (A) *GM* (B) *SM*  
(C) *GC* (D) *ML-MI*

**Question. 32**

A plate load test is carried out on a  $300 \text{ mm} \times 300 \text{ mm}$  plate placed at 2 m below the ground level to determine the bearing capacity of a  $2 \text{ m} \times 2 \text{ m}$  footing placed at same depth of 2 m on a homogeneous sand deposit extending 10 m below ground. The ground water table is 3 m below the ground level. Which of the following factors does not require a correction to the bearing capacity determined based on the load test ?

- (A) Absence of the overburden pressure during the test  
(B) Size of the plate is much smaller than the footing size  
(C) Influence of the ground water table  
(D) Settlement is recorded only over a limited period of one or two days

**Common Data for Questions 33 and 34 :**

Examine the test arrangement and the soil properties given below :

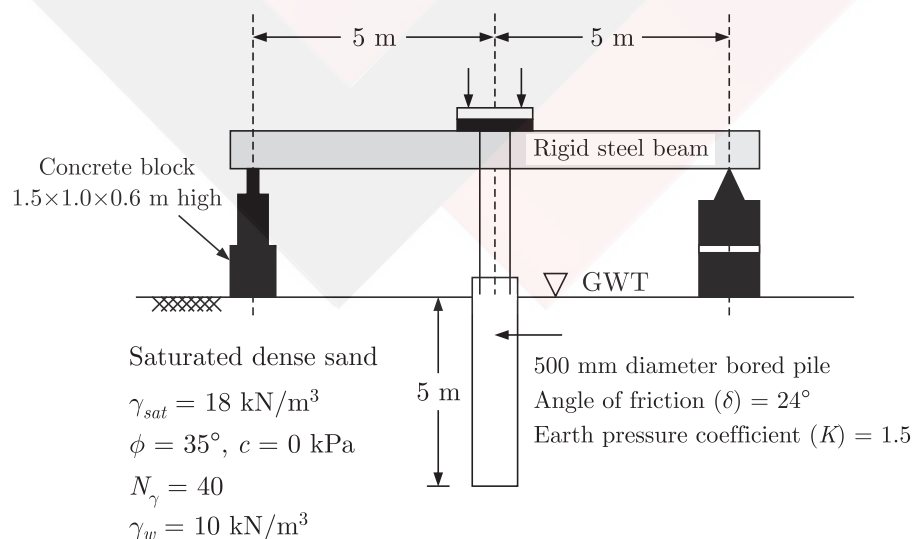

**Question. 33**

The maximum pressure that can be applied with a factor of safety of 3 through the concrete block, ensuring no bearing capacity failure in soil using Terzaghi's bearing capacity equation without considering the shape factor, depth factor and inclination factor is

- (A) 26.67 kPa (B) 60 kPa  
(C) 90 kPa (D) 120 kPa

**Question. 34**

The maximum resistance offered by the soil through skin friction while pulling out the pile from the ground is

- (A) 104.9 kN (B) 209.8 kN  
(C) 236 kN (D) 472 kN

**Statement for Linked Questions 35 and 36 :****Question. 35**

A saturated undisturbed sample from a clay strata has moisture content to 22.22% and specific weight of 2.7. Assuming  $\gamma_w = 10 \text{ kN/m}^3$ , the void ratio and the saturated unit weight of the clay, respectively are

- (A) 0.6 and 16.875 kN/m<sup>3</sup> (B) 0.3 and 20.625 kN/m<sup>3</sup>  
(C) 0.6 and 20.625 kN/m<sup>3</sup> (D) 0.3 and 16.975 kN/m<sup>3</sup>

**Question. 36**

Using the properties of the clay layer derived from the above question, the consolidation settlement of the same clay layer under a square footing (neglecting its self weight) with additional data shown in the figure below (assume the stress distribution as 1 H : 2 V from the edge of the footing and  $\gamma_w = 10 \text{ kN/m}^3$ ) is

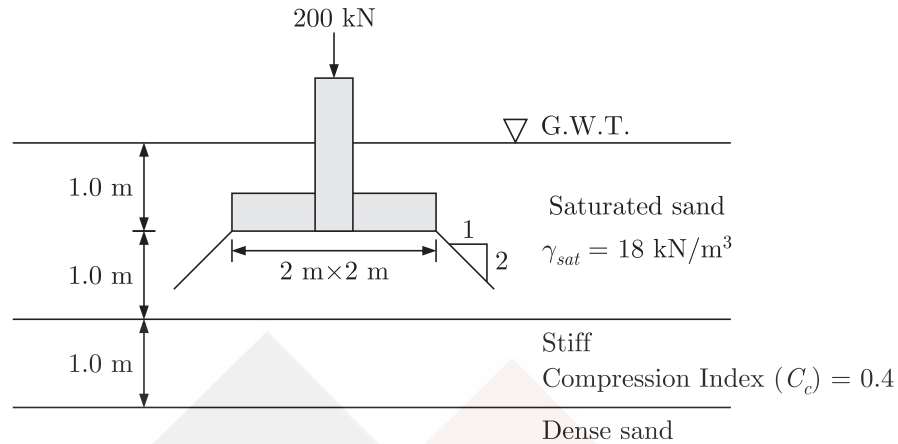

- (A) 32.78 mm                      (B) 61.75 mm  
 (C) 79.5 mm                        (D) 131.13 mm

**Question. 37**

The value of lateral friction or side friction used in the design of horizontal curve as per Indian Roads Congress guidelines is

- (A) 0.40                              (B) 0.35  
 (C) 0.24                              (D) 0.15

**Question. 38**

During a CBR test, the load sustained by a remolded soil specimen at 5.00 penetration is 50 kg. The CBR value of the soil will be

- (A) 10.0%                            (B) 5.0%  
 (C) 3.6%                              (D) 2.4%

**Question. 39**

In quadrantal bearing system, bearing of a line varies from

- (A)  $0^\circ$  to  $360^\circ$                       (B)  $0^\circ$  to  $180^\circ$   
 (C)  $0^\circ$  to  $90^\circ$                         (D)  $0^\circ\text{N}$  to  $90^\circ\text{S}$

**Question. 40**

Which of the flowing stress combinations are appropriate in identifying the critical condition for the design of concrete pavements ?

Type of stress	Location
a. Load	1. Corner
b. Temperature	2. Edge
	3. Interior

Select the correct answer using the codes given below :

- |              |              |
|--------------|--------------|
| (A) a-2, b-3 | (B) a-1, b-3 |
| (C) a-3, b-1 | (D) a-2, b-2 |

**Question. 41**

A crest vertical curve joins two gradients of + 3% and - 2% for a design speed of 80 km/h and the corresponding stopping sight distance of 120 m. The height of driver's eye and the object above the road surface are 1.20 m 0.15 m respectively. The curve length (which is less than stopping sight distance) to be provided is

- |           |           |
|-----------|-----------|
| (A) 120 m | (B) 152 m |
| (C) 163 m | (D) 240 m |

**Question. 42**

On a specific highway, the speed-density relationship follows the Greenbegs model  $[V = v_f \log_e(k_j k)]$ , where  $v_f$  and  $k_j$  are the free flow speed and jam density respectively. When the highway is operating at capacity, the density obtained as per this model is

- |                     |                     |
|---------------------|---------------------|
| (A) $ek_j$          | (B) $k_j$           |
| (C) $\frac{k_j}{2}$ | (D) $\frac{k_j}{e}$ |

**Question. 43**

A three-phase traffic signal at an intersection is designed for flows shown in the figure below. There are six groups of flows identified by the numbers 1 through 6. Among these 1, 3, 4 and 6 are through flows and 2 and 5 are right turning. Which phasing scheme is not feasible ?

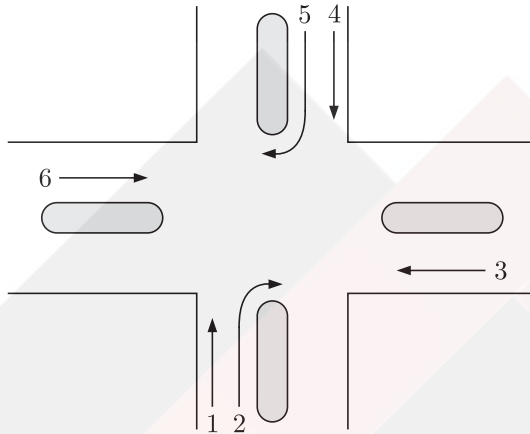

Combination choice	Phase I	Phase III	Phase III
P	1, 4	2, 5	3, 6
Q	1, 2	4, 5	3, 6
R	2, 5	1, 3	4, 6
S	2, 6	2, 6	3, 5

- (A) P
- (B) Q
- (C) R
- (D) S

**Question. 44**

The magnetic bearing of a line AB was N 59°30' W in the year 1967, when the declination was 4°10' E. If the present declination is 3° W, the whole circle bearing of the line is

- (A) 299°20'
- (B) 307°40'
- (C) 293°20'
- (D) 301°40'

**Question. 45**

Consider the following statements :

Assertion (A): Curvature correction must be applied when the sights are long.

Reason (R) : Line of collimation is not a level line but is tangential to the level line.

Of these statements

- (A) both A and R are true and R is the correct explanation of A
- (B) both A and R are true but R is not a correct explanation of A
- (C) A is true but R is false.
- (D) A is false but R is true.

**Question. 46**

The depth of flow in a alluvial channel is 1.5 m. If critical velocity ratio is 1.1 and Manning's  $n$  is 0.018, the critical velocity of the channel as per Kennedy's method is

- (A) 0.713 m/s
- (B) 0.784 m/s
- (C) 0.879 m/s
- (D) 1.108 m/s

**Question. 47**

An agricultural land of 437 ha is to be irrigated for a particular crop. The base period of the crop is 90 days and the total depth of water required by the crop is 105 cm. If a rainfall of 15 cm occurs during the base period, the duty of irrigation water is

- (A) 437 ha/cumec
- (B) 486 ha/cumec
- (C) 741 ha/cumec
- (D) 864 ha/cumec

**Common Data for Question 48 and 49**

One hour triangular unit hydrograph of a watershed has the peak discharge of  $60 \text{ m}^3/\text{sec}$  at 10 hours and time base of 30 hours. The  $\phi$  index is 0.4 cm per hour and base flow is  $15 \text{ m}^3/\text{sec}$ .

**Question. 48**

The catchment area of the watershed is

- (A)  $3.24 \text{ km}^2$  (B)  $32.4 \text{ km}^2$   
(C)  $324 \text{ km}^2$  (D)  $3240 \text{ km}^2$

**Question. 49**

If there is rainfall of 5.4 cm in 1 hour, the ordinate of the flood hydrograph at 15th hour is

- (A)  $225 \text{ m}^3/\text{sec}$  (B)  $240 \text{ m}^3/\text{sec}$   
(C)  $249 \text{ m}^3/\text{sec}$  (D)  $258 \text{ m}^3/\text{sec}$

**Question. 50**

The modulus of rupture of concrete in terms of its characteristic cube compressive strength ( $f_{ck}$ ) in MPa according to IS 456 : 2000 is

- (A)  $5000 f_{ck}$  (B)  $0.7 f_{ck}$   
(C)  $5000 \sqrt{f_{ck}}$  (D)  $0.7 \sqrt{f_{ck}}$

**Question. 51**

For limit state of collapse, the partial safety factors recommended by IS 456 : 2000 for estimating the design strength of concrete and reinforcing steel are respectively

- (A) 1.15 and 1.5 (B) 1.0 and 1.0  
(C) 1.5 and 1.15 (D) 1.5 and 1.0

**Question. 52**

A rectangular concrete beam of width 120 mm and depth 200 mm is prestressed by pre tensioning to a force of 150 kN at an eccentricity of 20 mm. The cross-sectional area of the prestressing steel is  $87.5 \text{ mm}^2$ . Take modulus of elasticity of steel and concrete as  $2.1 \times 10^5 \text{ MPa}$   $3.0 \times 10^4 \text{ MPa}$  respectively. The percentage loss of stress in the prestressing steel due to elastic deformation of concrete is

- (A) 8.75 (B) 6.125  
(C) 4.81 (D) 2.19



**Question. 53**

Match List-I (List of test methods for evaluating properties of concrete) with List-II (List of properties) and select the correct answer using the codes given below the lists :

List-I	List-II
a. Resonant frequency test	1. Tensile strength
b. Rebound hammer test	2. Dynamic modulus of elasticity
c. Split cylinder test	3. Workability
d. Compacting factor test	4. Compressive strength

Codes :

	a	b	c	d
(A)	2	4	1	3
(B)	2	1	4	3
(C)	2	4	3	1
(D)	4	3	1	2

**Question. 54**

A thin walled cylindrical pressure vessel having a radius of 0.5 m and wall thickness of 25 mm is subjected to an internal pressure of 700 kPa. The hoop stress developed is

- |              |               |
|--------------|---------------|
| (A) 14 MPa   | (B) 1.4 MPa   |
| (C) 0.14 MPa | (D) 0.014 MPa |

**Question. 55**

The point within the cross sectional plane of a beam through which the resultant of the external loading on the beam has to pass through to ensure pure bending without twisting of the cross-section of the beam is called

- |                   |                    |
|-------------------|--------------------|
| (A) moment centre | (B) centroid       |
| (C) shear centre  | (D) elastic center |

**Question. 56**

Consider the following statements :



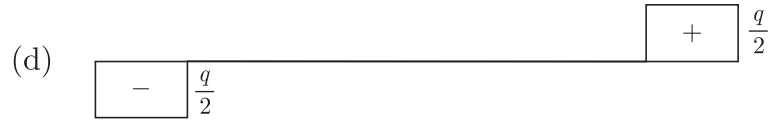
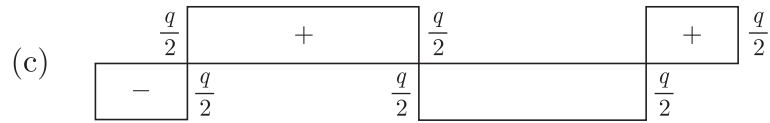

**List II**

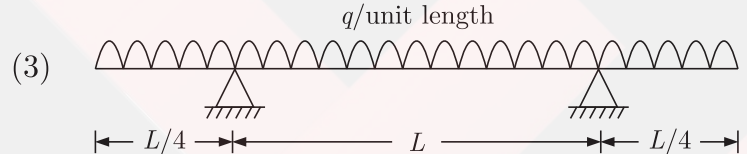
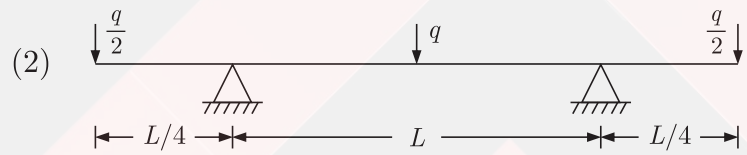
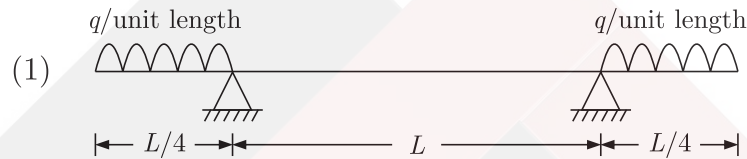

Codes :

	a	b	c	d
(A)	3	1	2	4
(B)	3	4	2	1

(C) 2 1 4 3

(D) 2 4 3 1

**Statement for Linked Answer Questions 59 & 60 :**

In the cantilever beam PQR shown in figure below, the segment PQ has flexural rigidity  $EI$  and the segment QR has infinite flexural rigidity

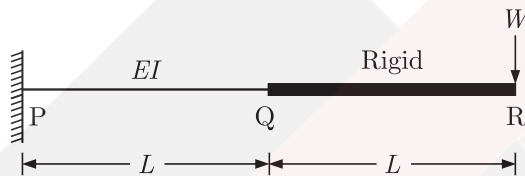
**Question. 59**

The deflection and slope of the beam at Q are respectively

(A)  $\frac{5WL^3}{6EI}$  and  $\frac{3WL^2}{2EI}$

(B)  $\frac{WL^3}{3EI}$  and  $\frac{WL^2}{2EI}$

(C)  $\frac{WL^3}{2EI}$  and  $\frac{WL^2}{EI}$

(D)  $\frac{WL^3}{3EI}$  and  $\frac{3WL^2}{2EI}$

**Question. 60**

The deflection of the beam at R is

(A)  $\frac{8WL^3}{EI}$

(B)  $\frac{5WL^3}{6EI}$

(C)  $\frac{7WL^3}{3EI}$

(D)  $\frac{8WL^3}{6EI}$

**Question. 61**

The degree of static indeterminacy of rigidity jointed frame in a horizontal plane and subjected to vertical load only, as shown in figure below, is

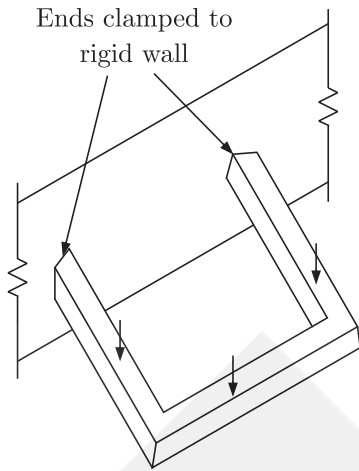

(A) 6

(B) 4

(C) 3

(D) 1

\*\*\*\*\*