

Question. 1

Consider the polynomial $p(x) = a_0 + a_1x + a_2x^2 + a_3x^3$, where $a_i \neq 0, \forall i$. The minimum number of multiplications needed to evaluate p on an input x is

- (A) 3 (B) 4
(C) 6 (D) 9

Question. 2

In a binary max heap containing n numbers, the smallest element can be found in time

- (A) $\theta(n)$ (B) $\theta(\log n)$
(C) $\theta(\log \log n)$ (D) $\theta(1)$

Question. 3

Consider a weighted complete graph G on the vertex set $\{v_1, v_2, \dots, v_n\}$ such that the weight of the edge (v_i, v_j) is $2|i - j|$. The weight of a minimum spanning tree of G is

- (A) $n - 1$ (B) $2n - 2$
(C) $\left(\frac{n}{2}\right)$ (D)

Question. 4

To implement Dijkstra's shortest path algorithm on unweighted graphs so that it runs in linear time, then data structure to be used is

- (A) Queue (B) Stack
(C) Heap (D) B-Tree

Question. 5

A scheme for storing binary trees in an array X is as follows. Indexing of X starts at 1 instead of 0. The root is stored at $X[1]$. For a node stored at $X[i]$, the left child, if any, is stored in $X[2i]$ and the right child, if any, in $X[2i + 1]$. To be able to store any binary tree on n vertices, the minimum size of X should be

- (A) $\log_2 n$ (B) n

(C) $2n + 1$ (D) $2n$ **Question. 6**

Which one the following in place sorting algorithms needs the minimum number of swaps?

(A) Quick-sort

(B) Insertion sort

(C) Selection sort

(D) Heap sort

Question. 7

Consider the following C-program fragment in which i, j , and n are integer variables.

```
for ( $i = n, j = 0; i > 0; i/2, j += i$ );
```

Let $\text{Val}(j)$ = denote the value stored in the variable j after termination of the for loop. Which one of the following is true?

(A) $\text{val}(j) = \theta(\log n)$ (B) $\text{val}(j) = \theta(\sqrt{n})$ (C) $\text{val}(j) = \theta(n)$ (D) $\text{val}(j) = \theta(n \log n)$ **Question. 8**

An element in an array X is called a leader if it is greater than all elements to the right of it in X . The best algorithm to find all leaders in an array.

(A) Solves it in linear time using a left to right pass of the array

(B) Solves in linear time using a right to left pass

(C) Solves it is using divide and conquer in time $\theta(n \log n)$ (D) Solves it in time $\theta(n^2)$ **Question. 9**

Consider the following graph:

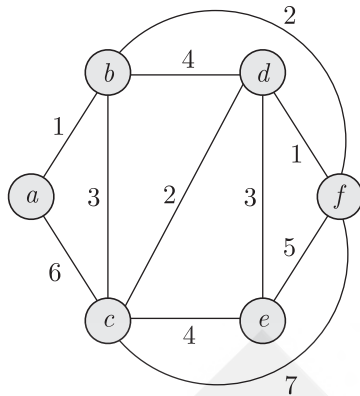

Which one of the following cannot be the sequence of edges added, in that order, to a minimum spanning tree using Kruskal's algorithm?

- (A) $(a - b), (d - f), (b - f), (d - c), (d - e)$
- (B) $(a - b), (d - f), (b - c), (b - f), (d - e)$
- (C) $(d - f), (a - b), (d - c), (d - e), (d - e)$
- (D) $(d - f), (a - b), (b - f), (d - e), (d - e)$

Question. 10

Let T be a depth first search tree in a undirected graph G . Vertices u and v are leaves of this tree T . The degrees of both u and v in G are at least 2. Which one of the following statements is true?

- (A) There must exist a vertex w adjacent to both u and v in G
- (B) There must exist a vertex w whose removal disconnects u and v in G
- (C) There must be exist a cycle in G containing u and v
- (D) There must exist a cycle in G containing u and all its neighbours in G

Question. 11

A set X can be represented by an array $x[n]$ as follows

$$x[i] = \begin{cases} 1 & \text{if } i \in X \\ 0 & \text{otherwise} \end{cases}$$

Consider the following algorithm in which x, y and z are boolean arrays of size n ;

Question. 14

Given two arrays of numbers a_1, \dots, a_n and b_1, \dots, b_n where each number is 0 or 1, the fastest algorithm to find the largest span (i, j) such that $a_i + a_{i+1} + \dots + a_j = b_i + b_{i+1} + \dots + b_j$, or report that there is no such span,

- (A) Takes $O(3^n)$ and $\Omega(2^n)$ time if hashing is permitted
- (B) Takes $O(n^3)$ and $W(n^{2.5})$ time in the key comparison model
- (C) Takes $\Theta(n)$ time and space
- (D) Takes $O(\sqrt{n})$ time only if the sum of the $2n$ elements is an even number

Question. 15

Consider the following code written in a pass-by reference language like FORTRAN and these statements about the code.

```
Subroutine swap (ix, iy)
    it = ix
L1 :    ix = iy
L2 :    iy = it
    end
    ia = 3
    ib = 8
    call swap (ia, ib + 5)
    print*, ia, ib
end
```

- S1: The compiler will generate code to allocate a temporary nameless cell, initialize it to 13, and pass the address of the cell to swap
- S2: On execution the code will generate a runtime error on line 1.1
- S3: On execution the code will generate a runtime error on line 1.2
- S4: The program will print 13 and 8
- S5: The program will print 13 and -2

Exactly the following set of statement (s) is correct:

- (A) S1 and S2
- (B) S1 and S4
- (C) S3
- (D) S1 and S5

Question. 16

Consider the following grammar.

$$\begin{aligned} S &\rightarrow S^* E \\ S &\rightarrow E \\ E &\rightarrow F + E \\ E &\rightarrow F \\ F &\rightarrow id \end{aligned}$$

Consider the following $LR(0)$ items corresponding to the grammar above.

- (i) $S \rightarrow S^* .E$
- (ii) $E \rightarrow F. + E$
- (iii) $E \rightarrow F + .E$

Given the items above, which two of them will appear in the same set in the canonical sets-of-items for the grammar?

- (A) (i) and (ii)
- (B) (ii) and (iii)
- (C) (i) and (iii)
- (D) None of these

Question. 17

Consider the following grammar

$$\begin{aligned} S &\rightarrow FR \\ R &\rightarrow * S \mid \varepsilon \\ F &\rightarrow id \end{aligned}$$

In the predictive parser table, M , of the grammar the entries $M[S, id]$ and $M[R, \$]$ respectively

- (A) $\{S \rightarrow FR\}$ and $\{R \rightarrow \varepsilon\}$
- (B) $\{S \rightarrow FR\}$ and $\{\}$
- (C) $\{S \rightarrow FR\}$ and $\{R \rightarrow * S\}$
- (D) $\{F \rightarrow id\}$ and $\{R \rightarrow \varepsilon\}$

Question. 18

Consider the following translation scheme.

- | | |
|-----------------------------------|-----------------------------------|
| (C) $S \rightarrow ACCB$ | (D) $S \rightarrow AC \mid CB$ |
| $C \rightarrow aCb \mid \epsilon$ | $C \rightarrow aCb \mid \epsilon$ |
| $A \rightarrow aA \mid \epsilon$ | $A \rightarrow aA \mid a$ |
| $B \rightarrow Bb \mid \epsilon$ | $B \rightarrow bB \mid b$ |

Question. 21

In the correct grammar above, what is the length of the derivation (number of steps starting from S to generate the string $a^l b^m$ with $l \neq m$?

- | | |
|----------------------|----------------------|
| (A) $\max(l, m) + 2$ | (B) $l + m + 2$ |
| (C) $l + m + 3$ | (D) $\max(l, m) + 3$ |

Question. 22

For which one of the following reason: does Internet Protocol (IP) use the time-to-live (TTL) field in the IP datagram header?

- (A) Ensure packets reach destination within that time
- (B) Discard packets that reach later than that time
- (C) Prevent packets from looping indefinitely
- (D) Limit the time for which a packet gets queued in intermediate routers

Question. 23

Station A uses 32 byte packets to transmit messages to Station B using a sliding window protocol. The round trip delay between A and B is 80 milliseconds and the bottleneck bandwidth on the path between aA and B is 128 kbps. What is the optimal window size that A should use ?

- | | |
|---------|---------|
| (A) 20 | (B) 40 |
| (C) 160 | (D) 320 |

Question. 24

Two computers C1 and C2 are configured as follows. C1 has IP address 203. 197.2.53 and netmask 255.255. 128.0. C2 has IP address 203.197.75.201 and netmask 255.255.192.0. Which one of the following statements is true?

- (A) C1 and C2 both assume they are on the same network
- (B) C2 assumes C1 is on same network, but C1 assumes C2 is on a different network
- (C) C1 assumes C2 is on same network, but C2 assumes C1 is on a different network
- (D) C1 and C2 both assume they are on different networks

Question. 25

Station A needs to send a message consisting of 9 packets to Station B using a sliding window (window size 3) and go-back-n error control strategy. All packets are ready and immediately available for transmission. If every 5th packet that A transmits gets lost (but no acks from B ever get lost), then what is the number of packets that A will transmit for sending the message to B ?

- (A) 12
- (B) 14
- (C) 16
- (D) 18

Question. 26

For the given connection of LANs by bridges, which one of the following choices represents the depth first traversal of the a spanning tree of bridges?

- (A) B1,B5,B3,B4,B2
- (B) B1,B3,B5,B2,B4
- (C) B1,B5,B2,B3,B4
- (D) B1.B3.B4.B5.B2

Question. 27

Consider the correct spanning tree for the previous question. Let host H1 send out a broadcast ping packet. Which of the following options represents the correct for forwarding table on B3?

(A)

Hosts	Ports
H1,H2,H3,H4	3
H5,H6,H9,H10	1
H7,H8,H11,H12	2

(B)

Hosts	Port
H1, H2	4
H3, H4	3
H5, H6	1
H7, H8, H9, H10	2
H11, H12	

(C)

Hosts	Port
H1, H2, H3, H4	3
H5, H6, H9, H10	1
H7,H8, H11, H12	2

(D)

Hosts	Port
H1, H2, H3, H4	3
H5, H7, H9, H10	1
H7, H8, H11, H12	4

Question. 28

A CPU has a cache with block size 64 bytes. The main memory has k banks, each bank being c bytes wide. Consecutive c -byte chunks are mapped on consecutive banks with wrap-around. All the k banks can be accessed in parallel, but two accesses to the same bank must be serialized. A cache block access may involve multiple iterations of parallel bank accesses depending on the amount of data obtained by accessing all the k banks in parallel. Each iteration requires decoding the bank numbers to be accessed in parallel and this takes $k/2$ ns. The latency of one bank access is 80 ns. If $c = 2$ and $k=24$, then latency of retrieving a cache block starting at address zero from main memory is

- (A) 92 ns (B) 104 ns
 (C) 172 ns (D) 184 ns

Question. 29

A CPU has five-stages pipeline and runs at 1GHz frequency. Instruction fetch happens in the first stage of the pipeline. A conditional branch instruction computes the target address and evaluates the condition in the third stage of the pipeline. The processor stops fetching new instructions following a conditional branch until the branch outcome is known. A program executes 10^9 instructions out of which 20% are conditional branches. If each instruction takes one cycle to complete on average, then total execution time of the program is

- (A) 1.0 second (B) 1.2 seconds
(C) 1.4 seconds (D) 11.6 seconds

Question. 30

Consider a new instruction named branch-on-bit-set (mnemonic bbs). The instruction “bbs reg, pos, label” jumps to label if bit in position pos of register operand reg is one. a register is 32 bits wide and the bits are numbered 0 to 31, bit in position 0 being the least significant. Consider the following emulation of this instruction on a processor that does not have bbs implemented.

temp ← reg and mask

Branch to label if temp is non-zero

The variable temp is a temporary register. For correct emulation the variable mask must be generated by

- (A) mask ← $0x1 \ll pos$ (B) mask ← $0x\text{fffffff} \gg pos$
(C) mask ← pos (D) mask ← $0xf$

Data for Q. 31 & 32 are given below. Solve the problem and choose the correct answers.

Consider two cache organizations: The first one is 32 KB 2-way set associative with 32-bytes block size. The second one is of the same size but direct mapped. The size of an address is 32 bits in both cases A2-to-1 multiplexes has latency of $0.6 ns$ where a k -bit comparator has a latency of $k/10ns$. The hit latency of the set associative organization is h_1 while that of the direct mapped one is h_2 .

Question. 31

The value of h_1 is

- (A) $2.4ns$ (B) $2.3ns$
(C) $1.8ns$ (D) $1.7ns$

Question. 32

The value of h_2 is

- (A) $2.4ns$ (B) $2.3ns$
(C) $1.8ns$ (D) $1.7ns$

Data for Q. 33 & 34 are given below.

A CPU has a 32 KB direct mapped cache with 128-byte block size. Suppose A is a two dimensional array of size 512×512 with elements that occupy 8-bytes each. Consider the following two C code segments,

P_1 and P_2 ,

```
P1 : for (i=0;i<512;i++)
{
    for (j=0;j<512;j++)
    {
        x+=A[i][j];
    }
}
P2 : for (i=0;i<512;i++) {
    for (j=0;j<512;j++) {
        {x+=A[j][i];}
    }
}
```

P_1 and P_2 are executed independently with the same initial state, namely, the array A is not in the cache and i, j, x are in registers. Let the number of cache misses experienced by P_1 be M_1 and that for P_2 be M_2 .

Question. 33

The value of M_1 is

- (A) 0 (B) 2048
(C) 16384 (D) 262144

Question. 34

The value of the ratio M_1/M_2 is

- (A) 0 (B) 1/16
(C) 1/8 (D) -16

Question. 35

Consider the following log sequence of two transactions on a bank account, with initial balance 12000, that transfer 2000 to a mortgage payment and, then apply a 5% interest.

1. T1 start
2. T1 B old = 12000 new = 10000
3. T1 M old = 0 ne = 2000
4. T1 commit
5. T2 start
6. T2 B old = 10000 new = 10500
7. T2 commit

Suppose the database system crashed just before log record 7 is written. When the system is restarted, which one statement is true of the recovery procedure?

- (A) We must redo log record 6 to set B to 10500
(B) We must undo log record 6 to set B to 10000 and then redo log records 2 and 3
(C) We need not redo log records 2 and 3 because transaction T1 has committed
(D) We can apply redo and undo operations in arbitrary order because they are idempotent

base for which Query 1 and Query 2 return different row sets

- (C) There exist databases for which Query 3 returns strictly fewer rows than Query 2
 (D) There exist databases for which Query 4 will encounter an integrity violation at runtime

Question. 38

Consider the relation enrolled (student, course) in which (student, course) is the primary key, and the relation paid (student, amount) where student is the primary key. Assume no null values and no foreign keys or integrity constraints. Assume that amounts 6000, 7000, 8000, 9000 and 10000 were each paid by 20% of the students. Consider these query plans (Plan 1 on left, Plan 2 on right) to “list all courses taken by students who have paid more than x .”

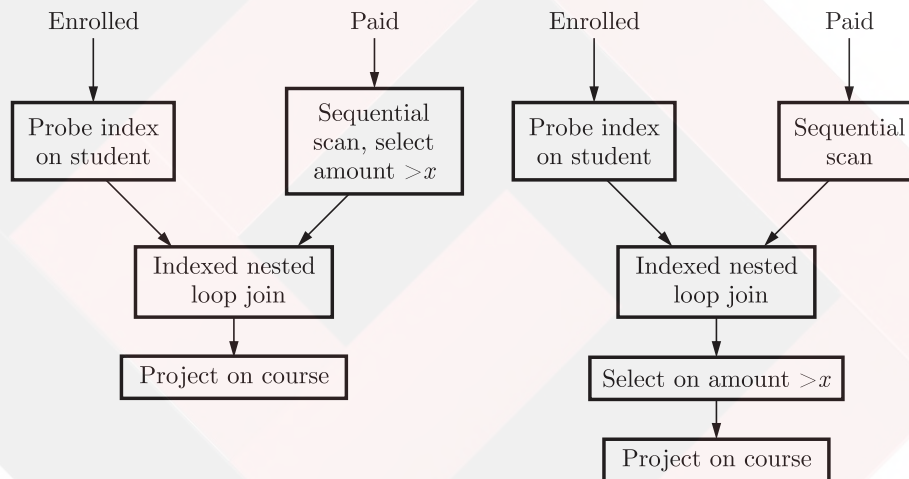

A disk seek takes 4 ms. disk data transfer bandwidth is 300 MB/s and checking a tuple to see if amount is greater x takes $10\mu s$. Which of the following statements is correct?

- (A) Plan 1 and Plan 2 will not output identical row sets for all databases
 (B) A course may be listed more than once in the output of Plan 1 for some databases
 (C) For $x = 5000$, Plan 1 executes faster than Plan 2 for all databases
 (D) For $x = 9000$, Plan 1 executes slower than Plan 2 for all databases

Question. 39

The following functional dependencies are given:

$AB \rightarrow CF, AF \rightarrow D, DE \rightarrow F, C \rightarrow G, F \rightarrow E, G \rightarrow A.$

Which one of the following options is false?

- (A) $\{CF\}^+ = \{ACFEFG\}$
- (B) $\{BG\}^+ = \{ABCDG\}$
- (C) $\{AF\}^+ = \{ACDEFG\}$
- (D) $\{AB\}^+ = \{ACDFG\}$

Question. 40

You are given a free running clock with a duty cycle of 50% and a digital waveform f which changes only at the negative edge of the clock. Which one of the following circuits (using clocked D flip flops) will delay the phase of f by 180° ?

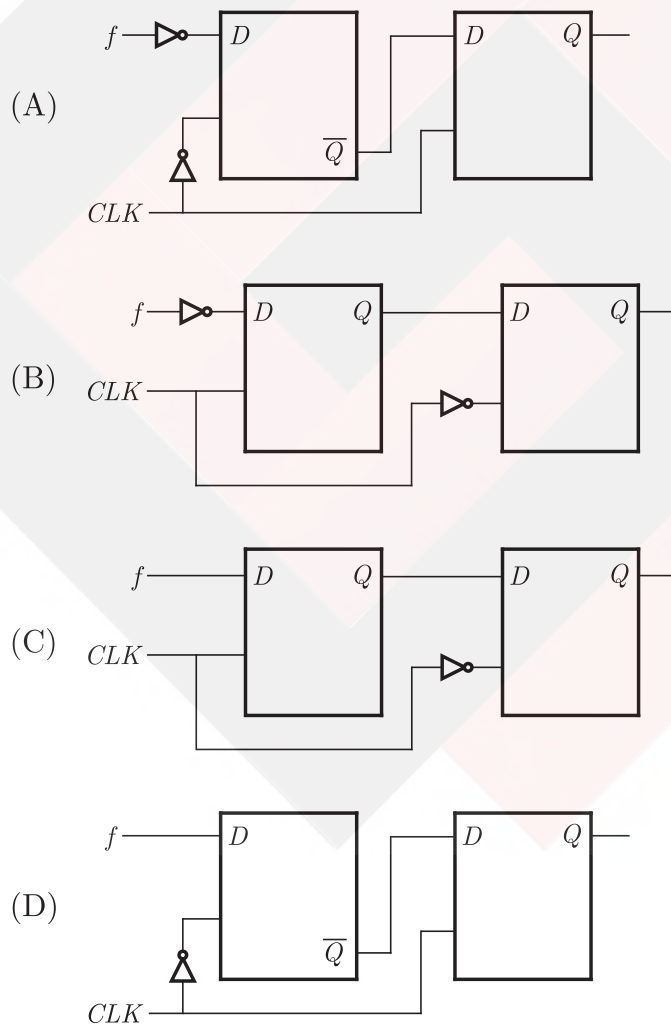

Question. 41

Consider the circuit below. Which one of the following options correctly represents $f(x, y, z)$?

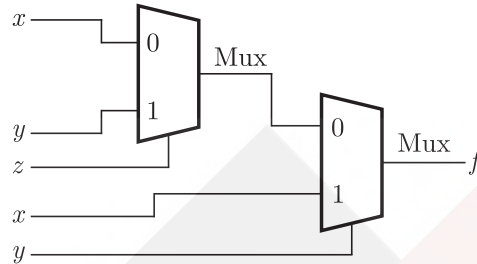

- (A) $x\bar{z} + xy + \bar{y}z$ (B) $x\bar{z} + xy + y\bar{z}$
 (C) $xz + xy + \bar{y}z$ (D) $xz + x\bar{y} + \bar{y}z$

Question. 42

Given two three bit numbers $a_2 a_1 a_0$ and $b_2 b_1 b_0$ and c , the carry in, the function that represents the carry generate function when these two numbers are added is

- (A) $a_2 b_2 + a_1 a_1 b_1 + a_2 a_1 a_0 b_0 + a_2 a_0 b_1 b_0 + a_1 b_2 b_1 + a_1 a_0 b_2 b_0 + a_0 b_2 b_1 b_0$
 (B) $a_2 b_2 + a_2 b_1 b_0 + a_2 a_1 b_1 b_0 + a_1 a_0 b_2 b_1 + a_1 a_0 b_2 + a_1 a_0 b_2 b_0 + a_2 a_0 b_1 b_0$
 (C) $a_2 + b_2 + (a_2 \oplus b_2)[a_1 + b_1 + (a_1 \oplus b_1)(a_0 + b_0)]$
 (D) $a_2 b_2 + \bar{a}_2 a_1 b_1 + \bar{a}_2 \bar{a}_1 a_0 b_0 + \bar{a}_2 a_0 \bar{b}_1 b_0 + a_1 \bar{b}_2 b_1 \bar{a}_1 a_0 \bar{b}_2 b_0 + a_0 \bar{b}_2 \bar{b}_1 b_0$

Question. 43

Consider a boolean function $f(w, x, y, z)$. Suppose that exactly one of its inputs is allowed to change at a time. If the function happens to be true for two input vectors $i_1 + \langle w_1, x_1, y_1, z_1 \rangle$ and $i_2 + \langle w_2, x_2, y_2, z_2 \rangle$, we would like the function to remain true as the input changes from i_1 to i_2 (i_1 and i_2 differ in exactly one bit position), without becoming false momentarily. Let $f(w, x, y, z) = \sum(5, 7, 11, 12, 13, 15)$. Which of the following cube covers of f will ensure that the required property is satisfied?

- (A) $\bar{w}xz, wx\bar{y}, x\bar{y}z, xyz, wyz$ (B) $wxy, \bar{w}xz, wyz$
 (C) $wx\bar{y}z, xz, w\bar{x}y$ (D) $wzy, wyz, wxz, \bar{w}\bar{w}xz, x\bar{y}z, xyz$

Question. 44

We consider addition of two 2's complement numbers $b_{n-1}b_{n-2}\dots b_0$ and $a_{n-1}a_{n-2}\dots a_0$. A binary adder for adding unsigned binary numbers is used to add the two numbers. The sum is denoted by $c_{n-1}c_{n-2}\dots c_0$ and the carryout by c_{out} . Which one of the following options correctly identifies the overflow condition?

- (A) $c_{out}(\overline{a_{n-1} \oplus b_{n-1}})$ (B) $a_{n-1}b_{n-1}\overline{c_{n-1}} + \overline{a_{n-1}b_{n-1}c_{n-1}}$
 (C) $c_{out} \oplus c_{n-1}$ (D) $a_{n-1} \oplus b_{n-1} \oplus c_{n-1}$

Question. 45

Consider number represented in 4-bit gray code. Let $h_3h_2h_1h_0$ be the gray code representation of a number n and let $g_3g_2g_1g_0$ be the gray code of $(n+1)$ (modulo 16) value of the number. Which one of the following functions is correct?

- (A) $g_0(h_1h_2h_1h_0) = \sum(1,2,3,6,10,13,14,15)$
 (B) $g_1(h_1h_2h_1h_0) = \sum(4,9,10,11,12,,13,14,15)$
 (C) $g_2(h_1h_2h_1h_0) = \sum(2,4,5,6,7,12,,13,15)$
 (D) $g_3(h_1h_2h_1h_0) = \sum(0,1,6,7,10,11,12,,13,)$

Question. 46

Let X, Y, Z be sets of sizes x, y and z respectively. Let $W = X \times Y$ and E be the set of all subsets of W . The number of functions from Z to E is

- (A) z (B) $z \times 2^{xy}$
 (C) z (D) 2^{xyz}

Question. 47

The set $\{1,2,3,5,7,8,9\}$ under multiplication modulo 10 is not a group. Given below are four plausible reasons. Which one of them is false?

- (A) It is not closed
 (B) 2 does not have an inverse
 (C) 3 does not have an inverse
 (D) 8 does not have an inverse

Question. 48

A relation R is defined on ordered pairs of integers as follows

$(x, y) R(u, v)$ if $x < u$ and $y > v$. Then R is

- (A) Neither a Partial Order nor an Equivalence Relation
- (B) A Partial Order but not a Total Order
- (C) A Total Order
- (D) An Equivalence Relation

Question. 49

Which one of the first order predicate calculus statements given below correctly expresses the following English statement?

- (A) $\forall x[(\text{tiger}(x) \wedge \text{lion}(x)) \rightarrow \{(\text{hungry}(x) \vee \text{threatened}(x)) \rightarrow \text{attacks}(x)\}]$
- (B) $\forall x[(\text{tiger}(x) \vee \text{lion}(x)) \rightarrow \{(\text{hungry}(x) \vee \text{threatened}(x)) \wedge \text{attacks}(x)\}]$
- (C) $\forall x[(\text{tiger}(x) \vee \text{lion}(x)) \rightarrow \{(\text{attacks}(x) \rightarrow (\text{hungry}(x) \wedge \text{Threatened}(x))\}]$
- (D) $\forall x[(\text{tiger}(x) \vee \text{lion}(x)) \rightarrow \{(\text{hungry}(x) \wedge \text{Threatened}(x)) \rightarrow \text{attacks}(x)\}]$

Question. 50

Consider the following propositional statements:

$$P1:((A \wedge B) \rightarrow C) \equiv ((A \rightarrow C) \wedge (B \rightarrow C))$$

$$P2:((A \vee B) \rightarrow C) \equiv ((A \rightarrow C) \vee (B \rightarrow C))$$

Which one of the following is true?

- (A) P1 is a tautology, but not P2
- (B) P2 is a tautology, but not P1
- (C) P1 and P2 are both tautologies
- (D) Both P1 and P2 are not tautologies

Question. 51

For each element in set of size $2n$, an unbiased coin is tossed. The $2n$ coin tossed are independent. An element is chosen if the corresponding coin toss were head. The probability that exactly n elements are chosen is

- (A) $\binom{2n}{n} / 4^n$ (B) $\binom{2n}{n} / 2^n$
 (C) $1 / \binom{2n}{n}$ (D) $\frac{1}{2}$

Question. 52

Let E, F and G be finite sets.

Let $X = (E \cap F) - (F \cap G)$ and $Y = (E - (E \cap G)) - (E - F)$. Which one of the following is true?

- (A) $X \subset Y$ (B) $X \supset Y$
 (C) $X = Y$ (D) $X - Y \neq \emptyset$ and $Y - X \neq \emptyset$

Question. 53

Let $S = \{1, 2, 3, \dots, m\}$ $m > 3$. Let X_1, \dots, X_n be subsets of S each of size 3. Define a function f from S to the set of natural numbers as, $f(i)$ is the number of sets X_j that contain the element i .

That is $f(i) = |\{j \mid i \in X_j\}|$.

Then $\sum_{i=1}^m f(i)$ is

- (A) $3m$ (B) $3n$
 (C) $sm + 1$ (D) $2n + 1$

Question. 54

40. A logical binary relation \odot , is defined as follows

A	B	$A \odot B$
True	True	True
True	False	True
False	True	False
False	False	True

Let \sim be the unary negation (NOT) operator, with higher precedence, than \odot . Which one of the following is equivalent to $A \wedge B$?

- (A) $(\sim A \odot B)$ (B) $\sim(A \odot \sim B)$
 (C) $\sim(\sim A \odot \sim B)$ (D) $\sim(\sim A \odot B)$

Question. 55

Given a set of elements $N = \{1, 2, \dots, n\}$ and two arbitrary subsets $A \subseteq N$ and $B \subseteq N$, how many of the $n!$ permutations π from N to N satisfy $\min[\pi(A)] = \min\{\pi(B)\}$, where \min

(S) is the smallest integer in the set of integers S . and $\pi(S)$ is the set of integers obtained

by applying permutation π to each element of S ?

- (A) $(n - |A \cup B|) |A| |B|$
 (B) $(|A| + |B|) n^2$
 (C) $n! \frac{|A \cap B|}{|A \cup B|}$
 (D) $\frac{|A \cap B|^2}{\binom{n}{|A \cup B|}}$

Data for Q. 56, 57 & 58 are given below.

Solve the problems and choose the correct answers.

The 2^n vertices of graph G correspond to all subsets of a set of size n , for $n \geq 6$. Two vertices of G are adjacent if and only if the corresponding sets intersect in exactly two elements.

Question. 56

The number of vertices of degree zero in G is

- (A) 1 (B) n
(C) $n + 1$ (D) 2^n

Question. 57

The maximum degree of a vertex in G is

- (A) $\left\lceil \frac{n}{2} \right\rceil 2^{n/2}$ (B) 2^{n-2}
(C) $2^{n-3} \times 3$ (D) 2^{n-1}

Question. 58

The number of connected components in G is

- (A) n (B) $n + 2$
(C) $2^{n/2}$ (D) $\frac{2^n}{n}$

Question. 59

F is an $n \times n$ real matrix. b is an $n \times 1$ real vector. Suppose there are two $n \times 1$ vectors, u and v such that $u \neq v$, and $Fu = b, Fv = b$.

Which one of the following statements is false?

- (A) Determinant of F is zero
(B) There are an infinite number of solutions to $Fx = b$
(C) There is an $x \neq 0$ such that $Fx = 0$
(D) F must have two identical rows

Question. 60

Consider three CPU-intensive processes, which require 10, 20 and 30 time units and arrive

- (A) 11 bits (B) 13 bits
(C) 15 bits (D) 20 bits

Question. 63

A computer system supports 32-bit virtual addresses as well as 32-bit physical addresses, Since the virtual address space is of the same size as the physical address space, the operating system designers decide to get rid of the virtual entirely. Which one of the following is true?

- (A) Efficient implementation of multi-user support is no longer possible
(B) The processor cache organization can be made more efficient now
(C) Hardware support for memory management is no longer needed
(D) CPU scheduling can be made more efficient now

Question. 64

Consider three processes (process *id* 0,1,2, respectively) with compute time bursts 2,4, and 8 time units. All processes arrive at time zero. Consider the longest remaining time first (LRTF) scheduling algorithm. In LRTF ties are broken by giving priority to the process with the lowest process *id*. The average turn around time is

- (A) 13 units (B) 14 units
(C) 15 units (D) 16 units

Question. 65

Consider three processes, all arriving at time zero, with total execution time of 10, 20 and 30 units, respectively. Each process spends the first 20% of execution time doing I/O, the next 70% of time doing computation, and the last 10% of time doing I/O again. The operating system uses a shortest remaining compute time first scheduling algorithm and schedules a new process either when the running process get blocked on I/O or when the running process finishes its compute burst. Assume that all I/O operations can be overlapped as much as possible. For what percentage of time does the CPU remain idle?

- (A) 0% (B) 10.6%
(C) 30.0% (D) 89.4%

Question. 66

Consider the following snapshot of a system running n processes. Process i is holding x_i instances of a resource R , for $1 \leq i \leq n$. Currently, all instances of R are occupied. Further, for all i , process i has placed a request for an additional y_i instances while holding the x_i instances it already has. There are exactly two processes p and q such that $y_p = y_q = 0$. Which one of the following can serve as a necessary condition to guarantee that the system is not approaching a deadlock?

- (A) $\min(x_p, x_q) < \max_{k \neq p, q} y_k$ (B) $x_p + x_q \leq \max_{k \neq p, q} y_k$
 (C) $\min(x_p, x_q) < 1$ (D) $\min(x_p, x_q) > 1$

Data for Q. 67 & 68 are given below.

Barrier is a synchronization construct where a set of processes synchronizes globally i.e. each process in the set arrives at the barrier and waits for all others to arrive and then all processes leave the barrier. Let the number of processes in the set be three and S be a binary semaphore with the usual P and V functions. Consider the following C implementation of a barrier with line numbers shown on the left.

```
Void barrier(void) {
1   :   P(S)
2   :   Process_arrived++;
3   :   V (S) :
4   :   while (process_arrived' = 3);
5   :   P(S);
6   :   Precess_left++;
7   :   if(process_left == 3)
8   :       process_arrived = 0;
9   :       process_left = 0;
10  :   }
11  :   V(S);
}
```

The variable `process_arrived` and `process_left` are shared among all processes and are initialized to zero. In a concurrent program all the three processes call the barrier function when they need to synchronize globally.

Question. 67

The above implementation of barrier is incorrect. Which one of the following is true?

- (A) The barrier implementation is wrong due to the use of binary semaphore S
- (B) The barrier implementation may lead to a deadlock if two barrier invocations are used in immediate succession
- (C) Lines 6 to 10 need not be inside a critical section
- (D) The barrier implementation is correct if there are only two processes instead of three

Question. 68

Which one of the following rectifies the problem in the implementation?

- (A) lines 6 to 10 are simply replaced by `process_arrived`
- (B) At the beginning of the barrier the first process to enter the barrier waits until `process_arrived` becomes zero before proceeding to execute `P(S)`
- (C) Context switch is disabled at the beginning of the barrier and re-enabled at the end.
- (D) The variable `process_left` is made private instead of shared

Question. 69

An implementation of a queue Q, using two stacks S1 and S2, is given below

```
void insert(Q,x){
    push (S1,x);
}
void delete(Q, x){
    if (stack-empty (S2))then
        if (stack-empty (S1))then{
            print("Q is empty");
            return;
        }
    else while (! (stack-empty)(S1)){
        x=pop(S1);
        push(S2,x);
    }
    x=pop(S2);
}
```

Let n insert and $m (\leq n)$ delete operations be performed in an arbitrary on an empty queue Q , Let x and y be the number of push and pop operations performed respectively in the processes. Which one of the following is true for all m and n ?

- (A) $n + m \leq x < 2n$ and $2m \leq n + m$
- (B) $n + m \leq x < 2n$ and $2m \leq y \leq 2n$
- (C) $2m \leq x < 2n$ and $2m \leq y \leq n + m$
- (D) $2m \leq x < 2n$ and $2m \leq y \leq 2n$

Question. 70

Consider the following C-function in which $a[n]$ and $b[n]$ are two sorted integer arrays and $c[n+m]$ be another integer array.

```
void xyz (int a[],int b[],int c[]){
    int i, j, k;
    i=j=k=0;
    while((i<n)&&(j<m))
        if (a[i]<b[j])c[k++]=a[i++];
        else c[k++]=b[j++];
}
```

Which of the following condition (s) hold (s) after the termination of the while loop ?

- I $j < m$, $k = n + j - 1$, and $a[n-1] < b[j]$ if $i = n$
- II $i < n$, $k = m + j - 1$, and $b[m-1] \leq a[i]$ if $j = m$

- (A) only (I)
- (B) only (II)
- (C) either (I) or (II) but not both
- (D) neither (I) nor (II)

Question. 71

Consider these two functions and two statements S1 and S2 about them.

```

int work1(int *a,int i,int j)   int work2(int *a,int i,int j)
{
    int x = a[i + 2];           {
    a[j] = x + 1;               int t1=i+2;
    return a[i + 2] - 3;}       int t2=a[t1];
                                a[j]=t2+1
                                return t2-3;
                                }

```

- S1: The transformation from work 1 to work 2 is valid, i.e., for any program state and input arguments, work 2 will compute the same output and have the same effect on program state as work 1
- S2: All the transformations applied to work 1 to get work 2 will always improve the performance (i.e. reduce CPU time) of work 2 compared to work 1
- (A) S1 is false and S2 is false
- (B) S1 is false and S2 is true
- (C) S1 is true and S2 is false
- (D) S1 is true and S2 is true

Question. 72

Consider the C code to swap two integers and these five statements: the code

```

void swap(int *px,int *py){
    *px=*px-*py;
    *py=*px+*py;
    *px=*py-*px;
}

```

- S_1 : will generate a compilation error
- S_2 : may generate a segmentation fault at runtime depending on the arguments passed
- S_3 : correctly implements the swap procedure for all input pointers referring to integers stored in memory locations accessible to the process
- S_4 : implements the swap procedure correctly for some but not all valid input pointers
- S_5 : may add or subtract integers and pointers
- (A) S_1 (B) S_2 and S_3
- (C) S_2 and S_4 (D) S_2 and S_5

Data for Q. 73 & 74 are given below.

A 3-ary max heap is like a binary max heap, but instead of 2 children, nodes have 3 children. A 3-ary heap can be represented by an array as follows: The root is stored in the first location, $a[0]$, nodes in the next level, from left to right, is stored from $a[1]$ to $a[3]$. The nodes from the second level of the tree from left to right are stored from $a[4]$ location onward.

An item x can be inserted into a 3-ary heap containing n items by placing x in the location $a[n]$ and pushing it up the tree to satisfy the heap property.

Question. 73

Which one of the following is a valid sequence of elements in an array representing 2-ary max heap ?

- (A) 1, 3, 5, 6, 8, 9 (B) 9, 6, 3, 1, 8, 5
(C) 9, 3, 6, 8, 5, 1 (D) 9, 5, 6, 8, 3, 1

Question. 74

Suppose the elements 7, 2, 10, and 4 are inserted, in that order, into the valid 3-ary max heap found in the above question, Q. 33. Which one of the following is the sequence of items in the array representing the resultant heap ?

- (A) 10, 7, 9, 8, 3, 1, 5, 2, 6, 4
(B) 10, 9, 8, 7, 6, 5, 4, 3, 2, 1
(C) 10, 9, 4, 5, 7, 6, 8, 2, 1, 3
(D) 10, 8, 6, 9, 7, 2, 3, 4, 1, 5

Question. 75

Let S be an NP -complete problem Q and R be two other problems not known to be in NP . Q is polynomial-time reducible to S and S is polynomial-time reducible to R . Which one of the following statements is true?

- (A) R is NP -complete (B) R is NP -hard
(C) Q is NP -complete (D) Q is NP -hard

Question. 76

Let $L_1 = \{0^{n+m}1^n0^m \mid n, m \leq 0\}$, $L_2 = \{0^{n+m}1^{n+m}0^m \mid n, m \leq 0\}$, and $L_3 = \{0^{n+m}1^{n+m}0^{n+m} \mid n, m \leq 0\}$. Which of these languages are NOT context free?

- (A) L_1 only (B) L_3 only
(C) L_1 and L_2 (D) L_2 and L_3

Question. 77

If s is a string over $(0+1)^*$, then let $n_0(s)$ denote the number of 0's in s and $n_1(s)$ the number of 1's in s . Which one of the following languages is not regular?

- (A) $L = \{s \in (0+1)^* \mid n_0(s) \text{ is a 3-digit prime}\}$
(B) $L = \{s \in (0+1)^* \mid \text{for every prefixes' of } s, |n_0(s') - n_1(s')| \leq 2\}$
(C) $L = \{s \in (0+1)^* \mid n_0(s) - n_1(s) \leq 4\}$
(D) $L = \{s \in (0+1)^* \mid n_0(s) \bmod 7 = n_1(s) \bmod 5 = 0\}$

Question. 78

For $s \in (0+1)^*$ let $d(s)$ denote the decimal value of s (e.g. $d(101) = 5$)

Let $L = \{s \in (0+1)^* \mid d(s) \bmod 5 = 2 \text{ and } d(s) \bmod 7 \neq 4\}$

Which one of the following statements is true?

- (A) L is recursively enumerable, but not recursive
(B) L is recursive, but not context-free
(C) L is context_free, but not regular
(D) L is regular

Question. 79

Let SHAM, be the problem of finding a Hamiltonian cycle in a graph $G = (V, E)$ with $|V|$ divisible by 3 and DHAM' be the problem of determining if a Hamiltonian cycle exists in such graphs. Which one of the following is true?

- (A) Both DHAM, and SHAM, are NP-hard

- (B) SHAM, is NP-hard, but DHAM, is not
- (C) DHAM, is NP-hard, but SHAM, is not
- (D) Neither DHAM,nor SHAM, is NP-hard

Question. 80

Consider the following statements about the context-free grammar,

$$G = \{S \rightarrow SS, S \rightarrow ab, S \rightarrow ba, S \rightarrow \epsilon\}$$

1. G is ambiguous.
2. G produces all strings with equal number of a 's and b 's.
3. G can be accepted by a deterministic PDA .

Which combination below expresses all the true statements about G ?

- (A) 1 only
- (B) 1 and 3 only
- (C) 2 and 3 only
- (D) 1, 2 and 3

Question. 81

Let L_1 be regular language, L_2 be a deterministic context-free language and L_3 a recursively enumerable, but not recursive, language. Which one of the following statements is false?

- (A) $L_1 \cap L_2$ is a deterministic CFL
- (B) $L_3 \cap L_1$ is recursive
- (C) $L_1 \cup L_2$ is context free
- (D) $L_1 \cap L_2 \cap L_3$ is recursively enumerable

Question. 82

Consider the regular language $L = (111 + 111111)^*$. The minimum number of states in any DFA accepting this languages is

- (A) 3
- (B) 5
- (C) 8
- (D) 9