

Question. 1

The height of a binary tree is the maximum number of edges in any root to leaf path. The maximum number of nodes in a binary tree of height h is

- (A) 2^h (B) $2^{h-1} - 1$
(C) $2^{h+1} - 1$ (D) 2^{h+1}

Question. 2

The maximum number of binary trees that can be formed with three unlabeled nodes is

- (A) 1 (B) 5
(C) 4 (D) 3

Question. 3

Which of the following sorting algorithms has the lowest worst-case complexity?

- (A) Merge sort (B) Bubble sort
(C) Quick sort (D) Selection sort

Question. 4

The inorder and preorder traversal of a binary tree are

$dbaefcg$ and $abdecfg$ respectively

The postorder traversal of the binary tree is

- (A) $debf gca$ (B) $edbgfca$
(C) $edbf gca$ (D) $defg bca$

Question. 5

Consider the hash table of size seven, with starting index zero, and a hash function $(3x + 4)$ and 7. Assuming the hash table is initially empty, which of the following is the contents of the table when the sequence 1,3,8,10 is inserted into the table using closed hashing?

Note that \emptyset denotes an empty location in the table

- (A) 8, \emptyset , \emptyset , \emptyset , \emptyset , \emptyset , 10
 (B) 1, 8, 10, \emptyset , \emptyset , \emptyset , 3
 (C) 1, \emptyset , \emptyset , \emptyset , \emptyset , \emptyset , 3
 (D) 1, 10, 8, \emptyset , \emptyset , 3

Question. 6

In an unweighted, undirected connected graph, the shortest path from a node S to every other node is computed most efficiently, in terms of time complexity, by

- (A) Dijkstra's algorithm starting from S .
 (B) Warshall's algorithm
 (C) performing a DFS starting from S
 (D) performing a BFS starting from S

Question. 7

A complete n -ary tree is a tree in which each node has n children or no children. Let I be the number of internal nodes and L be the number of leaves in a complete n -ary tree. If $L = 41$, and $I = 10$, what is the value of n

- (A) 3
 (B) 4
 (C) 5
 (D) 6

Question. 8

In the following C function, let $n \leq m$.

```
int gcd (n, m)
{
    if(n&m == 0) return m;
    n = n&m;
    return gcd(m, n);
}
```

How many recursive calls are made by this function?

- (A) $\Theta(\log_2 n)$
 (B) $\Omega(n)$
 (C) $\Theta(\log_2 \log_2 n)$
 (D) $\Theta(\sqrt{n})$

Question. 9

What is the time complexity of the following recursive function :

```
intDoSomething(int n)    {  
    if      n <= 2  
        return 1;  
    else  
        return (DoSomething(floor(sqrt(n))  
        )+ n);  
    }
```

- (A) $\Theta(n^2)$ (B) $\Theta(n \log_2 n)$
(C) $\Theta(\log_2 n)$ (D) $\Theta(\log_2 \log_2 n)$

Question. 10

Consider the process of inserting an element into a Max Heap, where the Max Heap is represented by an array. Suppose we perform a binary search on the path from the new leaf to the root to find the position for the newly inserted element, the number of comparisons performed is

- (A) $\theta(\log_2 n)$ (B) $\theta(\log_2 \log_2 n)$
(C) θn (D) $\theta(n \log_2 n)$

Question. 11

Let w be the minimum weight among all edge weights in an undirected connected graph, Let e be a specific edge of weight w . Which of the following is FALSE ?

- (A) There is a minimum spanning tree containing e .
(B) If e is not in a minimum spanning tree T , then in the cycle formed by adding e to T , all edges have the same weight.
(C) Every minimum spanning tree has an edge of weight w
(D) e is present in every minimum spanning tree

Question. 12

An array of n numbers is given, where n is an even number. The maximum as well as the minimum of these n numbers needs to be determined. Which of the following is TRUE about the number of comparisons needed?

- (A) At least $2n-c$ comparisons, for some constant c , are needed,
- (B) At most $1.5n-2$ comparisons are needed.
- (C) At least $n, \log_2 n$ comparisons are needed.
- (D) None of the above

Question. 13

Consider the following C code segment:

```
int    IsPrime(n)
{
    int i,n;
    for (i = 2; i <= sqrt(n); i++)
    if (n%i == 0)
    print("Not Prime\n");
    return 0;
}
return 1;
```

Let $T(n)$ denote the number of times the for loop is executed by the program on input n . Which of the following is TRUE?

- (A) $T(n) = O(\sqrt{n})$ and $T(n) + \Omega(\sqrt{n})$
- (B) $T(n) = O(\sqrt{n})$ and $T(n) + \Omega(1)$
- (C) $T(n) = O(n)$ and $T(n) = \Omega(\sqrt{n})$
- (D) None of these

Data for Q. 14 & 15 are given below.

Solve the problems and choose the correct answers.

Suppose the letters a, b, c, d, e, f have probabilities $\frac{1}{2}, \frac{1}{4}, \frac{1}{8}, \frac{1}{16}, \frac{1}{32}$ respectively.

Question. 14

Which of the following is the Hoffman code for the letters a, b, c, d, e, f ?

- (A) 0, 10, 110, 1110, 11110, 11111
- (B) 11, 10, 011, 010, 001, 000
- (C) 11, 10, 01, 001, 0001, 0000
- (D) 110, 100, 010, 000, 111

Question. 15

What is the average length of the correct answer to Q. ?

- (A) 3
- (B) 2.1875
- (C) 2.25
- (D) 1.781

Question. 16

Which one of the following is a top-down parser?

- (A) Recursive descent parser
- (B) Operator precedence parser
- (C) An LR(k) parser
- (D) An LALR(k) parser

Question. 17

Consider the grammar with non-terminals $N = \{S, C, S_1\}$, terminals

$T = \{a, b, i, t, e\}$, with S as the start symbol, and the following of rules

$$S \rightarrow iCtSS_1 \mid a$$

$$S_1 \rightarrow eS \mid \varepsilon$$

$$C \rightarrow b$$

The grammar is NOTLL(1) because:

- (A) It is left recursive (B) It is right recursive
 (C) It is ambiguous (D) It is not context-free

Question. 18

Consider the following two statements:

P: Every regular grammar is LL(1)

Q: Every regular set has LR(1) grammar

Which of the following is TRUE?

- (A) Both *P* and *Q* are true (B) *P* is true and *Q* is false
 (C) *P* is false and *Q* is true (D) Both *P* and *Q* are false

Question. 19

In a simplified computer the instructions are:

OP R_j, R_i – Performs $R_j \text{ OP } R_i$ and stores the result in register R_i

OP m, R_i – Performs $\text{val OP } R_i$ and stores the result in R_i . *val* denotes the content of memory location m .

MCM, R_i – Moves the content of memory location m to register R_i .

MCM, R_i, m – Moves the content of register R_i to memory location m .

The computer has only two registers, and *OP* is either ADD or SUB. Consider the following basic block:

$$\begin{aligned} t_1 &= a + b \\ t_2 &= c + d \\ t_3 &= e - t_2 \\ t_4 &= t_1 - t_2 \end{aligned}$$

Assume that all operands are initially in memory. The final value of the computation should be in memory. What is the minimum number of MOV instructions in the code generated for this basic block?

- (A) 2 (B) 3
(C) 5 (D) 6

Data for Q. 20 & 21 are given below.

Solve the problems and choose the correct answers.

Consider the CFG with $\{S, A, B\}$ as the non-terminal alphabet, $\{a, b\}$ as the terminal alphabet, S as the start symbol and the following set of production rules

$s \rightarrow bA$	$S \rightarrow aB$
$A \rightarrow a$	$B \rightarrow b$
$A \rightarrow aS$	$B \rightarrow bS$
$A \rightarrow bAA$	$B \rightarrow aBB$

Question. 20

Which of the following strings is generated by the grammar?

- (A) $aaaabb$ (B) $aabbbb$
(C) $aabbab$ (D) $abbbba$

Question. 21

For the correct answer string to Q. 9 how many derivation trees are there?

- (A) 1 (B) 2
(C) 3 (D) 4

Question. 22

In Ethernet when manchester encoding is used, the bit rate is

- (A) Half the baud rate (B) Twice the baud rate

- (C) Same as the baud rate (D) None of these

Question. 23

Which one of the following uses UDP as the transport protocol?

- (A) HTTP (B) Telnet
(C) DNS (D) SMTP

Question. 24

There are n stations in a slotted LAN. Each station attempts to transmit with a probability p in each time slot. What is the probability that ONLY one station transmits in a given time slot?

- (A) $np(1-p)^{n-1}$ (B) $(1-p)^{n-1}$
(C) $p(1-p)^{n-1}$ (D) $1 - (1-p)^{n-1}$

Question. 25

In a token ring network the transmission speed is 10 bps and the propagation speed is 200 metres/ μ s. The 1-bit delay in this network is equivalent to;

- (A) 500 metres of cable (B) 200 metres of cable
(C) 20 metres of cable (D) 50 metres of cable

Question. 26

The address of a class B host is to be split into subnets with a 6-bit subnet number. What is the maximum number of subnets and the maximum number of hosts in each subnet?

- (A) 62 subnets and 262142 hosts (B) 64 subnets and 262142 hosts
(C) 62 subnets and 1022 hosts (D) 64 subnets and 1024 hosts

Question. 27

The message 11001001 is to be transmitted using the CRC polynomial $x^3 + 1$ to protect it from errors. The message that should be transmitted is:

- (A) 11001001000 (B) 11001001011
 (C) 11001010 (D) 110010010011

Question. 28

The distance between two stations M and N is L kilo metres. All frames are K bits long. The propagation delay per kilo metre is t seconds. Let R bits/second be the channel capacity. Assuming that processing delay is negligible, the minimum number of bits for the sequence number field in a frame for maximum utilization, when the sliding window protocol is used, is;

- (A) $\left\lceil \log_2 \frac{2LtR + 2K}{K} \right\rceil$ (B) $\left\lceil \log_2 \frac{2LtR}{K} \right\rceil$
 (C) $\left\lceil \log_2 \frac{2LtR + K}{K} \right\rceil$ (D) $\left\lceil \log_2 \frac{2LtR + K}{2K} \right\rceil$

Question. 29

Match the following:

- | | |
|---------|----------------------|
| P. SMTP | 1. Application layer |
| Q. BGP | 2. Transport layer |
| R. TCP | 3. Data link layer |
| S. PPP | 4. Network layer |
| | 5. Physical layer |
- (A) P-2,Q-1,R-3,S-5 (B) P-1,Q-4,R-2,S-3
 (C) P-1,Q-4,R-2,S-5 (D) P-2,Q-4,R-1,S-3

Question. 30

Consider a 4-way set associative cache consisting of 120 lines with a line size of 64 words. The CPU generates a 20-bit address of a word in main memory. The number of bits in the TAG, LINE and WORD fields are respectively

- (A) 9,6,5 (B) 7,7,6
 (C) 7,5,8 (D) 9,5,6

Question. 31

Consider a disk pack with 16 surfaces, 128 tracks per surface and 256 sectors per track. 512 bytes of data are stored in a bit serial manner in a sector. The capacity of the disk pack and the number of bits required to specify a particular sector in the disk are respectively

- (A) 256 Mbytes, 19 bits (B) 256 Mbyte, 28 bits
 (C) 512 Mbytes, 20 bits (D) 64 Gbyte, 28 bits

Question. 32

Consider a pipelined processor with the following four stages

IF: Instruction Fetch
 ID: Instruction Decode and Operand Fetch
 EX: Execute
 WB: Write Bank

The IF, ID and WB stages take one clock cycle each to complete the operation. The number of clock cycles for the EX stage depends on the instruction. The ADD and SUB instructions need 1 clock cycle and the MUL instruction need 3 clock cycles in the EX stage. Operand forwarding is used in the pipelined processor. What is the number of clock cycles taken to complete the following sequence of instructions?

ADD	R2,	R1,	R0	$R2 \leftarrow R1 + R0$
MUL	R4,	R3,	R2	$R4 \leftarrow R3 * R2$
SUB	R6,	R5,	R4	$R6 \leftarrow R5 - R4$

- (A) 7 (B) 8
 (C) 10 (D) 14

Data for Q. 33, 34 & 35 are given below.

Consider the following program segment. Here R1, R2 and R3 are the general purpose registers.

Instruction	Operation	Instruction size (no. of words)
MOV R1, (3000)	$R1 \leftarrow M[3000]$	2
LOOP:		
MOV R2, R1	$R2 \leftarrow M[R3]$	1
ADD R2, R1	$R2 \leftarrow R1 + R2$	1
MOV (R3), R2	$M[R3] \leftarrow R2$	1
INC R3	$R3 \leftarrow R3 + 1$	1
DEC R1	$R1 \leftarrow R1 - 1$	1
BNZ LOOP	Branch on not zero	2
HALT	Stop	

Assume that the content of memory location 3000 is 10 and the content of the register R3 is 2000. The content of each of the memory locations from 2000 to 2010 is 100. The program is loaded from the memory location 100. All the numbers are in decimal.

Question. 33

Assume that the memory is word addressable. The number of memory references for accessing the data in executing the program completely is

- (A) 10 (B) 11
(C) 20 (D) 21

Question. 34

Assume that the memory is word addressable. After the execution of this program, the content of memory location 2010 is

- (A) 100 (B) 101
(C) 102 (D) 110

Question. 35

Assume that the memory is byte addressable and the word size is 32 bits. If an interrupt occurs during the execution of the instruction "INC R3", what return address will be pushed on to the stack?

- (A) 1005 (B) 1020

(C) 1024

(D) 1040

Data for Q. 36 & 37 are given below.

Consider a machine with a byte addressable main memory of 2^{16} bytes. Assume that a direct mapped data cache consisting of 32 lines of 64 bytes each is used in the system. A 50×50 two-dimensional array of bytes is stored in the main memory starting from memory location 1100H. Assume that the data cache is initially empty. The complete array is accessed twice. Assume that the contents of the data cache do not change in between the two accesses.

Question. 36

How many data cache misses will occur in total?

(A) 48

(B) 50

(C) 56

(D) 59

Question. 37

Which of the following lines of the data cache will be replaced by new blocks in accessing the array

(A) line 4 to line 11

(B) line 4 to line 12

(C) line 0 to line 7

(D) line 0 to line 8

Question. 38

Information about a collection of students is given by the relation `studInfo` (studId, name, sex). The relation `enroll` (studID, CourseId) gives which student has enrolled for (or taken) what course(s). Assume that every course is taken by at least one male and at least one female student. What does the following relational algebra expression represent?

$$\Pi_{\text{courseId}}((\Pi_{\text{studId}}(\sigma_{\text{sex}=\text{"female"}}(\text{studInfo})) \times \Pi_{\text{courseId}}(\text{enroll})) - \text{enroll})$$

(A) Courses in which all the female students are enrolled

(B) Courses in which a proper subset of female students are enrolled

(C) Courses in which only male students are enrolled

(D) None of the above.

Question. 39

Consider the relation employee (name, sex, supervisorName (with name as the key. supervisor Name-gives the name of the supervisor of the employee under consideration. What does the following Tuple Relational Calculus query produce?

$$\{e.name \mid \text{employee}(e) \wedge$$

$$(\forall x) [\neg \text{employee}(x) \vee x.\text{supervisorName}$$

$$\neq e.name \vee x.sex = \text{"male"}]\}$$

- (A) Names of employees with a male supervisor
- (B) Names of employees with no immediate male subordinates
- (C) Names of employees with no immediate female subordinates
- (D) Names of employees with a female supervisor

Question. 40

Consider the table employee (empId, name, department, salary) and the two queries Q_1, Q_2 below. Assuming that department 5 has more than one employee, and we want to find the employees who get higher salary than anyone in the department 5, which one of the statements is TRUE for any arbitrary employee table?

Q_1 : Select e. empId

From employee e

Where not exists

(Select*From employee s Where s. department="5" and s.salary >= e.salary)

Q_2 : Select e. empId

From employee e

Where e.salary > Any

(Select distinct salary From employee s Where s. department="5")

- (A) Q_1 is the correct query.
- (B) Q_2 is the correct query
- (C) Both Q_1 and Q_2 produce the same answer
- (D) Neither Q_1 nor Q_2 is the correct query

Question. 41

Which one of the following statements is FALSE?

- (A) Any relation with two attributes is in BCNF
- (B) A relation in which every key has only one attribute is in 2NF
- (C) A prime attribute can be transitively dependent on a key in 3NF relation
- (D) A prime attribute can be transitively dependent on a key in a BNCF relation.

Question. 42

The order of a leaf node in a B^+ -tree is the maximum number of (value, data record pointer) pairs it can hold. Given that the block size is 1K bytes, data record pointer is 7 bytes long, the value field is 9 bytes long and a block pointer is 6 bytes long, what is the order of the leaf node?

- (A) 63
- (B) 64
- (C) 67
- (D) 68

Question. 43

Consider the following schedules involving two transactions. Which one of the following statements is TRUE?

$S_1: r_1(X); r_1(Y); r_2(X); r_2(Y); w_2(Y); w_1(X)$

$S_2: r_1(X); r_2(X); r_2(Y); w_2(Y); r_1(Y); w_1(X)$

- (A) Both S_1 and S_2 are conflict serializable
- (B) S_1 is conflict serializable and S_2 is not conflict serializable
- (C) S_1 is not conflict serializable and S_2 is conflict serializable

(D) Both S_1 and S_2 are not conflict serializable

Question. 44

What is the maximum number of different Boolean functions involving n Boolean variables?

- (A) n^2 (B) 2^n
(C) 2^{2^n} (D) 2^{n^2}

Question. 45

How many 3-to-8 line decoders with an enable input are needed to construct a 6-to-64 line decoder without using any other logic gates?

- (A) 7 (B) 8
(C) 9 (D) 10

Question. 46

Consider the following Boolean function of four variables

$$f(w, x, y, z) = \sum (1, 3, 4, 6, 9, 11, 12, 14)$$

The function is

- (A) independent of one variable
(B) independent of two variables
(C) independent of three variables
(D) dependent on all the variables

Question. 47

Let $f(w, x, y, z) = \sum (0, 4, 5, 7, 8, 9, 13, 15)$. Which of the following expressions are NOT equivalent to f ?

- (A) $x'y'z + w'xy' + wy'z + xz$ (B) $w'y'x' + wx'y' + xz$

$$(C) w'y'z' + wx'y' + xyz + xy'z \qquad (D) x'y'z + wx'y' + w'y$$

Question. 48

Define the connective* for the boolean variable X and Y as: $X * Y = XY + X'Y'$

Let $Z = X * Z$

Consider the following expression P, Q and R .

$$P: X = Y * Z \quad Q: Y = X * Z$$

$$R: X * Y * Z = 1$$

Which of the following is TRUE?

- (A) only P and Q are valid (B) Only Q and R are valid
 (C) Only P and R are valid (D) All P, Q, R are valid

Question. 49

Suppose only one multiplexer and one inverter are allowed to be used to implement any Boolean function of n variables. What is the minimum size of the multiplexer needed?

- (A) 2^n line to 1 line (B) 2^{n+1} line to 1 line
 (C) 2^{n-1} line to 1 line (D) 2^{n-2} line to 1 line

Question. 50

In a look-ahead carry generator, the carry generate function G_i and the carry propagate function P_i for inputs, A_i and B_i are given by $P_i = A_i \oplus B_i$ and $G_i = A_i B_i$

The expressions for the sum bit S and carry bit C_{i+1} of the look ahead carry adder are given by

$$S_i + P_i \oplus C_i \text{ and } C_{i+1} G_i + P_i C_i, \text{ Where } C_0 \text{ is the input carry.}$$

Consider a two-level logic implementation of the look-ahead carry generator.. Assume that all P_i and G_i are available for the carry generator circuit and that the AND and OR gates

can have any number of inputs. The number of AND gates and OR gates needed to implement the look-ahead carry generator for a 4-bit adder with S_3, S_2, S_1, S_0 and C_4 as its outputs are respectively

- (A) 6,3 (B) 10,4
(C) 6,4 (D) 10,5

Question. 51

The control signal functions of 4-bit binary counter are given below

(where X is “don’t care”)

Clear	Clock	Load	Count	Function
1	X	X	X	Clear to 0
0	X	0	0	No change
0	↑	1	X	Load input
0	↑	0	1	Count next

The counter is connected as follows

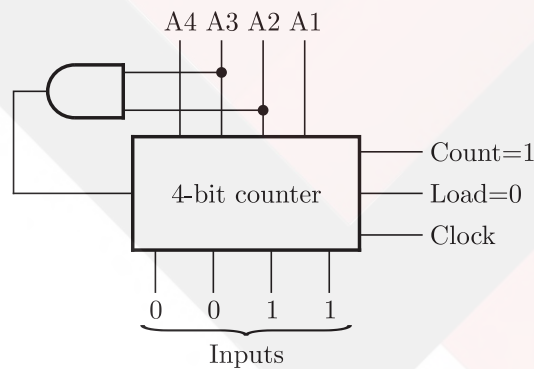

Assume that the counter and gate delays are negligible. If the counter starts at 0, then it cycles through the following sequence

- (A) 0,3,4 (B) 0,3,4,5
(C) 0,1,2,3,4 (D) 0,1,2,3,4,5

Question. 52

Let S be a set of n elements. The number of ordered pairs in the largest and the smallest equivalence relations on S are

- (A) n and n (B) n^2 and n
 (C) n^2 and 0 (D) n and 1

Question. 53

Let G be the non-planar graph with the minimum possible number of edges. Then G has.

- (A) 9 edges and 5 vertices (B) 9 edges and 6 vertices
 (C) 10 edges and 5 vertices (D) 10 edges and 6 vertices

Question. 54

Consider the DAG with $V = \{1, 2, 3, 4, 5, 6\}$, shown below

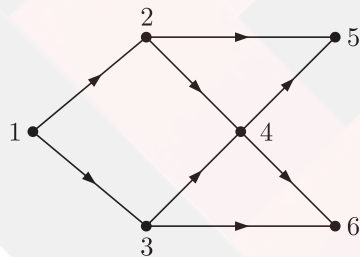

Which of the following is NOT a topological ordering?

- (A) 1 2 3 4 5 6 (B) 1 3 2 4 5 6
 (C) 1 3 2 4 5 6 (D) 3 2 4 1 6 5

Question. 55

Consider the following two statements about the function $f(x) = |x|$

$P: f(x)$ is continuous for all real values of x

$Q: f(x)$ is differentiable for all real values of x

Which of the following is TRUE?

- (A) P is true and Q is false (B) P is false and Q is true
(C) Both P and Q are true (D) Both P and Q are false

Question. 56

Let Graph (x) be a predicate which denotes that x is a graph. Let connected (x) be a predicate which denotes that x is connected. Which of the following first order logic sentences DOES NOT represent the statement; ‘Not every graph is connected’?

- (A) $\neg \forall x (\text{Graph}(x) \Rightarrow \text{Connected}(x))$
(B) $\exists x (\text{Graph}(x) \wedge \neg \text{Connected}(x))$
(C) $\neg \forall x (\neg \text{Graph}(x) \vee \text{Connected}(x))$
(D) $\forall x (\text{Graph}(x) \Rightarrow \neg \text{Connected}(x))$

Question. 57

Which of the following is TRUE about formulae in Conjunctive Normal Form

- (A) For any formula, there is a truth assignment for which at least half the clauses evaluate to true.
(B) For any formula, there is a truth assignment for a which all the clauses evaluate to true.
(C) For is a formula such that for each truth assignment at most one-fourth of the clauses evaluate to true.
(D) None of the above.

Question. 58

Suppose we uniformly and randomly select a permutation from the $20!$ permutations of 1, 2, 3,.....20. What is the probability that 2 appears at an earlier position than any other even number in the selected permutation?

- (A) $\frac{1}{2}$ (B) $\frac{1}{10}$
(C) $\frac{9!}{20!}$ (D) None of these

Question. 59

How many different non-isomorphic Abelian groups of order 4 are there?

- (A) 2
- (B) 3
- (C) 4
- (D) 5

Question. 60

Consider the set $S = \{a, b, c, d\}$. Consider the following 4 partitions $\pi_1, \pi_2, \pi_3, \pi_4$, on

$$S: \pi_1 = \{\overline{abcd}\}, \pi_2 = \{\overline{ab}, \overline{cd}\}, \pi_3 = \{\overline{abc}, \overline{d}\},$$

$$\pi_4 = \{\overline{a}, \overline{b}, \overline{c}, \overline{d}\}$$

Let $<$ be the partial

order on the set of partitions $S' = (\pi_1, \pi_2, \pi_3, \pi_4)$ defined as follows: $\pi_i < \pi_j$ if and only if π_i refines π_j . The poset digram for $(S', <)$ is

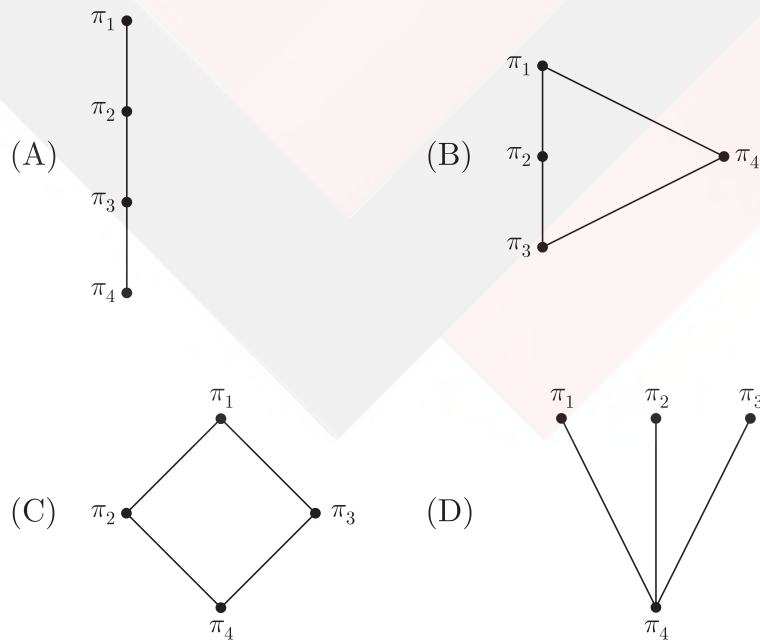

Data for Q. 61 & 62 are given below.

Solve the problems and choose the correct answers.

Suppose that a robot is placed on the Cartesian plane. At each step it is allowed to move either one unit up or one unit right, i.e., if it is at (i, j) then it can move to either $(i + 1, j)$ or $(i, j + 1)$.

Question. 61

How many distinct paths are there for the robot to reach the point $(10, 10)$ starting from the initial position $(0, 0)$?

(A) $\binom{20}{10}$

(B) 2^{20}

(C) 2^{10}

(D) None of these

Question. 62

Suppose that the robot is not allowed to traverse the line segment from $(4, 4)$ to $(5, 4)$. With this constraint, how many distinct paths are there for the robot to reach $(10, 10)$ starting from $(0, 0)$?

(A) 2^9

(B) 2^{19}

(C) $\binom{8}{4} \times \binom{11}{5}$

(D) $\binom{20}{10} - \binom{8}{4} \times \binom{11}{5}$

Question. 63

Which of the following graphs has an Eulerian circuit?

(A) Any k -regular graph where k is an even number

(B) A complete graph on 90 vertices

(C) The complement of a cycle on 25 vertices

(D) None of the above

Question. 64

Let A be a 4×4 matrix with eigenvalues $= 5, -2, 1, 4$. Which of the following is an eigenvalue of

$$\begin{bmatrix} A & I \\ I & A \end{bmatrix}$$

Where I is the 4×4 identity matrix?

- (A) -5 (B) -7
 (C) 2 (D) 1

Question. 65

Consider the set of (column) vectors defined $tyX = \{x \in R^3 \mid x_1 + x_2 + x_3 = 0 \text{ where } x^T = [x_1, x_2, x_3]^T\}$.

Which of the following is TRUE?

- (A) $\{[1, -1, 0]^T, [1, 0, -1]^T\}$ is a basis for the subspace X .
 (B) $\{[1, -1, 0]^T, [1, 0, -1]^T\}$ is a linearly independent set, but it does not span X and therefore is not a basis of X .
 (C) X is not a subspace for R^3 .
 (D) None of the above

Question. 66

Consider the series $x_{n+1} = \frac{x_n}{2} + \frac{9}{8x_n}$, $x_0 = 0.5$ obtained from the Newton-Raphson method. The series converges to

- (A) 1.5 (B) $\sqrt{2}$
 (C) 1.6 (D) 1.4

Question. 67

Group-1 contains some CPU scheduling algorithms and group-2 contains some applications. Match entries in Group-1 entries in Group-2

Group-1

Group-2

P. Gang Scheduling

1. Guaranteed Scheduling

Q. Rate Monotonic Scheduling

2. Real-time Scheduling

R. Fair Share scheduling

3. Thread Scheduling

(A) P-3;Q-2;R-1

(B) P-1;Q-2;R-3

(C) P-2;Q-3;R-1

(D) P-1;Q-3;R-2

Question. 68

Consider the following statements about user level threads and kernel level threads. Which one of the following statements is FALSE?

- (A) Context switch time is longer for kernel level threads than for user level threads
- (B) User level threads do not need any hardware support
- (C) Related kernel level thread can be scheduled on different processors in a multiprocessor system
- (D) Blocking one kernel level thread blocks all related threads

Question. 69

An operating system uses Shortest Remaining Time first (SRT) process scheduling algorithm. Consider the arrival times and execution times for the following processes

Process	Execution time	Arrival time
P1	20	0
P2	25	15
P3	10	30

P4

15

45

What is the total waiting time for process P2?

- (A) 5 (B) 15
(C) 40 (D) 55

Question. 70

A virtual memory system uses first In First Out (FIFO) page replacement policy and allocates a fixed number of frames to a process. Consider the following statements:

P: Increasing the number of page frames allocated to a process sometimes increases the page fault rate.

Q: Some program do not exhibit locality of reference.

Which one of the following is TRUE?

- (A) Both P and Q are true, and Q is the reason for P
(B) Both P and Q are true, but Q is not the reason for P
(C) P is false, but Q is true
(D) Both P and Q are false

Question. 71

A single processor system has three resource types X , Y , and Z , which are shared by three processes. There are 5 units of each resource type. Consider the following scenario, where the column alloc denotes the number of units of each resource type allocated to each process, and the column request denotes the number of units of each resource type requested by a process in order to complete execution. Which of these processes will finish LAST?

	alloc	request
	X Y Z	X Y Z
P0	121	103
P1	201	012
P2	221	120

- (A) P0
- (B) P1
- (C) P2
- (D) None of the above, since the system is in a deadlock

Question. 72

Two processes, P1 and P2, need to access a critical section of code. Consider the following synchronization construct used by the processes:

```

/*P1*/
while (true) {
wants1=true;

while(wants2==true);

/* Critical
Section*/

wants 1 = false;
}

/* Remainder section*/

/*P2*/
while (true) {
wants2 = true;

while (wants1 == true);

/* Critical
Section*/

wants 2 = false;
}

/*Remainder section*/

```

Here, wants 1 and wants 2 are shared variables, Which are initialized to false. Which one of the following statements is TRUE about the above construct?

- (A) It does not ensure mutual exclusion.
- (B) It does not ensure bounded waiting.
- (C) It requires that processes enter the critical section in strict alternation.
- (D) It does not prevent deadlocks, but ensures mutual exclusion

Data for Q. 73 & 74 are given below.

A process has been allocated 3 page frames. Assume that none of the pages of the process are available in the memory initially. The process makes the following sequence of page references (reference string): 1,2,1,3,7,4,5,6,3,1.

Question. 73

If optimal page replacement policy is used, how many page faults occur for the above reference string?

- (A) 7
- (B) 8
- (C) 9
- (D) 10

Question. 74

Least Recently Used (LRU) page replacement policy is a practical approximation to optimal page replacement. For the above reference string, how many more page faults occur with LRU than with the optimal page replacement policy?

- (A) 0
- (B) 1
- (C) 2
- (D) 3

Question. 75

Consider the following segment of C-code

```
int j, n;  
j = 1;  
while (j <= n)  
j = j * 2;
```

The number of comparisons made in the execution of the loop for any $n > 0$ is

- (A) $\lfloor \log_2 n \rfloor + 1$ (B) n
 (C) $\lfloor \log_2 n \rfloor$ (D) $\lfloor \log_2 n \rfloor + 1$

Question. 76

The following postfix expression with single digit operands is evaluated using a stack

8 2 3 ^ / 2 3 * + 5 1 * -

Note that ^ is the exponentiation operator. The top two elements of the stack after the first * is evaluated are

- (A) 6, 1 (B) 5, 7
 (C) 3, 2 (D) 1, 5

Question. 77

Consider the following C function:

```
int f(int n)
    static int r=0;
    if (n <= 0) return 1;
    if (n > 3)
        {r = n;
         return f(n - 2) + 2;
        }
    return f(n - 1) + r;
}
```

What is the value of $f(5)$?

- (A) 5 (B) 7
 (C) 9 (D) 18

Question. 78

Consider the following C program segment where Cell Node represents a node in a binary tree

```

struct CellNode {
    struct CellNode*leftchild;
    int element;
    struct CellNode*rightchild;
};
int GetValue(struct CellNode * ptr) {
    int vlaue = 0;
    if (ptr!=NULL) {
        if ((ptr->leftChild == NULL)&&
            (ptr->rightChild == NULL))
            Value = 1;
        else
            value = value + GetValue
                    (ptr->leftChild)
                    +
                    Get Value
                    (ptr->rightChild);
    }
    return(value);
}

```

The value returned by Get Value when a pointer to the root of a binary tree is passed as its argument is

- (A) the number of nodes
- (B) the number of internal nodes in the tree
- (C) the number of leaf nodes in the tree
- (D) the height of the tree

Question. 79

Which of the following problems is undecidable?

- (A) Membership problem for *CFGs*
- (B) Ambiguity problem for *CFGs*
- (C) Finiteness problem for *FSA*s
- (D) Equivalence problem for *FSA*s

Question. 80

Which of the following is TRUE?

- (A) Every subset of a regular set is regular
- (B) Every finite subset of a non-regular set is regular

- (C) The union of two non-regular sets is not regular
(D) Infinite union of finite sets is regular

Question. 81

A minimum state deterministic finite automation accepting the language $L = \{w \mid w \in (0,1)^*$, number of 0s & 1s in w are divisible by 3 and 5, respectively} has

- (A) 15 states (B) 11 states
(C) 10 states (D) 9 states

Question. 82

The language $L = \{0^T 21^i \mid i \leq 0\}$ over the alphabet $\{0,1,2\}$ is

- (A) not recursive
(B) is recursive and is a deterministic *CFL*
(C) is a regular language
(D) is not a deterministic *CFI* but a *CFL*

Question. 83

Which of the following languages is regular?

- (A) $\{WW^R \mid W \in \{0,1\}^+\}$ (B) $\{WW^R X \mid X, W \in \{0,1\}^+\}$
(C) $\{WXW^R X \mid X, W \in \{0,1\}^+\}$ (D) $\{XWW^R X \mid X, W \in \{0,1\}^+\}$

Data for Q. 84 & 85 are given below

Solve the problems and choose the correct answers.

Consider the following Finite State Automation

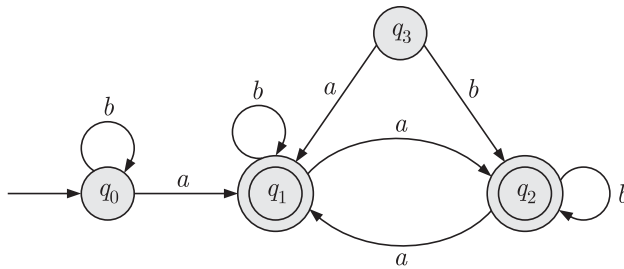
**Question. 84**

The language accepted by this automaton is given by the regular expression

- (A) $b^* ab^* ab^* ab^*$ (B) $(a + b)^*$
 (C) $b^* a(a + b)^*$ (D) $b^* ab^* ab^*$

Question. 85

The minimum state automaton equivalent to the above FSA has the following number of states

- (A) 1 (B) 2
 (C) 3 (D) 4
